

**PROJECT MANUAL BID FOR CITY OF TORRANCE PARK EXTERIOR LIGHTING  
RETROFIT**

**B2020-13**

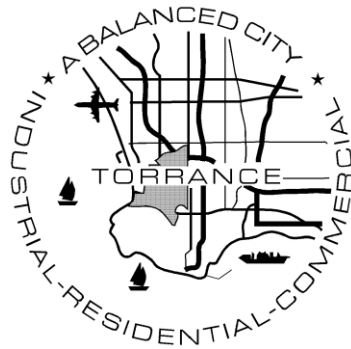

**May 2020**

## TABLE OF CONTENTS

	<u>Page No.</u>
<b>A. NOTICE INVITING BIDS</b>	<b>3</b>
<b>B. INSTRUCTIONS TO BIDDERS</b>	<b>7</b>
<b>C. SPECIAL PROVISIONS</b>	<b>16</b>
<b>D. BID DOCUMENTS</b>	<b>29</b>
Bidder's Proposal	
Addenda Acknowledgment	
Contractor's Affidavit	
Bid Bond (10% of Bid)	
List of Subcontractors	
References	
Bidders Information	
<b>E. DOCUMENTS TO BE COMPLETED AND DELIVERED TO THE CITY AS PART OF CONTRACT WITH CITY</b>	<b>42</b>
Performance Bond (100% of Bid)	
Labor and Material Bond (100% of Bid)	
Contract – Contract Services Agreement	
Verification of Insurance Coverage (Certificates and Endorsements)	
Business License Application	
<b>F. SPECIFICATIONS</b>	<b>61</b>
<b>G. AERIAL PHOTOS</b>	<b>84</b>
<b>H. PREVAILING WAGE DETERMINATIONS</b>	<b>102</b>

**PART A**  
**NOTICE INVITING BIDS**

**CITY OF TORRANCE  
CALIFORNIA**

**NOTICE INVITING BIDS**

Notice is hereby given that sealed bid proposals for performing the following described work will be received at the office of the City Clerk of the City of Torrance, California, until **3:00 p.m. on Wednesday, June 17, 2020. All bids would need to be mailed in, no walk-in bids will be accepted into the City Clerk's Office from the public. No bidders will be allowed at the bid opening.**

**BID FOR CITY OF TORRANCE PARK EXTERIOR LIGHTING RETROFIT B2020-13**

**A pre-bid conference will not be conducted. Addenda will be issued only by email and only to those who mailed in a bid.** All addenda must be acknowledged. Failure to acknowledge addenda on the bid forms provided may render the proposal non-responsive and cause it to be rejected.

The project manual, and bid proposal packet are available online for viewing and printing at: <https://www.torranceca.gov/government/general-services/completed-projects>

The bid proposal packet and bound specifications (project manual) may be obtained online or may be requested to be mailed. A \$5.00 fee, if requesting bid proposal packet to be mailed. A \$15.00 fee if requesting both bound specifications (project manual) and bid proposal packet by mail. All amounts include tax. No amount is refundable. A prospective bidder must provide to the City Clerk's office the firm's name, address, telephone and fax number, a contact person and a valid email address.

If requesting any item(s) by mail, please send check to the following:

**CITY OF TORRANCE  
OFFICE OF THE CITY CLERK  
3031 TORRANCE BLVD  
TORRANCE, CA 90503-2970  
ATTN: B2020-13**

Scope of work: The City of Torrance is seeking qualified contractors to upgrade its current exterior lighting at 17 park locations. The retrofit work must be accomplished in a professional and expedient manner.

The contractor must purchase and install the equipment specified on the Bid Proposal in Section "D". See also manufacturer specifications on Section "F". The contractor must follow the installation procedures outlined by the fixture manufacturer. The contractor will ensure the installation meets these installation procedures so as to resolve any potential glare, wiring or other issues that reduce performance or void warranty of the product. All



existing fixtures and associated components must be properly disposed to meet all federal, state and local requirements.

The Specifications in section F are intended to govern all aspects of the appurtenant construction including, but not limited to, materials, methods and details, except as modified herein or as inconsistent with the provisions hereof.

**Bidders may bid on all or part of these requirements as indicated on the price proposal. The City may award one or more contracts for these items to the lowest responsible bidder of each item or group of items. The City may award to one vendor if doing so is in the best interest of the City.**

The contract completion term will begin upon the receipt of the Notice to Proceed (NTP) and will remain in effect **for one hundred five (105) calendar days. The one hundred five (105) calendar days** schedule includes: completion of contractual paperwork, submittal review, lead time for materials, and onsite work. Bids are required for the entire work described herein.

**Bidders Examination of Requirements:**

The bidder is required to examine carefully the site, the instructions, information and specifications of this document, investigate the conditions to be encountered, the character, quality and quantities of work to be performed as required by this document. Submission of a bid will be considered prima facie evidence that the bidder has made such examination.

The successful bidder must have at the time of submitting the bid a valid C-10 Electrical Contracting License.

Bidder, as the prime contractor, must have successfully completed at least three (3) public works retrofit projects of a similar size and scope valued at \$100,000 for each project within the last three (3) years. Bidder must have at least five (5) years' experience under current license (California State License Board), company registration (California Secretary of State). References must reflect this experience.

The project estimate is between \$100,000 - \$120,000.

Per Division 2, Chapter 2 of the Torrance Municipal Code, the Torrance City Council may reject any and all bids, waive any informality or irregularity in such bids, and determine the lowest responsible bidder.

No Facsimile Bids shall be accepted by the City.

By order of the City Council of the City of Torrance, California.

This contract is subject to California State Prevailing Wage- Pursuant to Section 1771 and 1773 of the Labor Code, the general prevailing wage rates in the county in which the work is to be done have been determined by the Director of the California Department of

Industrial Relations. These wages are set forth in the General Prevailing Wage Rates for this project, are attached and available from the California Department of Industrial Relations' internet site at <http://www.dir.ca.gov/Public-Works/Prevailing-Wage.html>. Future effective general prevailing wage rates which have been predetermined and are on file with the California Department of Industrial Relations are referenced but not printed in the general prevailing wage rates.

APPRENTICESHIP EMPLOYMENT STANDARDS. Attention is directed to the provisions in Sections 1776 and 1777.5 of the California Labor Code concerning the employment of apprentices by the Contractor or any subcontractor under them.

One of the legal requirements for working on a public works project is the employment of apprentices. The Division of Apprenticeship Standards provides assistance to contractors in employing apprentices on public works sites.

Information relative to apprenticeship standards, wage schedules, and other requirements may be obtained from the Director of Industrial Relations, <http://www.dir.ca.gov/das/PublicWorksForms.htm>

Contractor Registration with the Department of Industrial Relations (SB 854)

- No contractor or subcontractor may be listed on a bid proposal or awarded a public works project unless registered with the Department of Industrial Relations pursuant to Labor Code section 1725.5 [with limited exceptions from this requirement for bid purposes only under Labor Code section 1771.1(a)].
- No contractor or subcontractor may be awarded a contract for public work on public works project unless registered with the Department of Industrial Relations pursuant to Labor Code section 1725.5.
- This project is subject to compliance monitoring and enforcement by the Department of Industrial Relations. All contractors and subcontractors must furnish electronic certified payroll records directly to the Labor Commissioner (aka Division of Labor Standards Enforcement). For additional information and to register online go to <http://www.dir.ca.gov/Public-Works/Contractors.html>

**Fall Protection: Roof – Safety Requirement** - OSHA requires employers to protect workers from falls. Falls can cause death and very serious injuries -and can be prevented. OSHA's fall protection requirements are as follows: for general industry, fall protection must be used while working at heights of four or more feet (see [www.osha.gov/SLTC/fallprotection/index.html](http://www.osha.gov/SLTC/fallprotection/index.html)). Fall protection can be accomplished through the use of guardrail systems, safety net systems, personal fall arrest systems, or similar systems.

**PART B**  
**INSTRUCTIONS TO BIDDERS**

**CITY OF TORRANCE  
CALIFORNIA**

**INSTRUCTIONS TO BIDDERS**

**A. QUALIFICATION OF BIDDERS**

1. Competency of Bidders

The Bidder shall be thoroughly competent and capable of satisfactorily performing the Work covered by the Bid. As specified in the Bid Documents, the Bidder shall furnish statements of previous experience on similar work. When requested, the Bidder shall also furnish a plan of procedure proposed; organization, machinery, plant and other equipment available for the Work; evidence of financial condition and resources; and any other documentation as may be required by the City to determine if the Bidder is responsible.

2. Contractor's License

At the time of submitting the Bid, the Bidder shall be licensed as a contractor in accordance with the provisions of Chapter 9, Division 3, of the California Business and Professions Code. The required prime contractor license class for the Work is shown in the project Notice Inviting Bids. However, the City reserves the right to award the Contract to a contractor with another class if the City determines that the license is proper for the work.

**B. BIDDER RESPONSIBILITY**

A responsible Bidder is a Bidder who has demonstrated the attribute of trustworthiness, as well as ability, fitness, capacity and experience to satisfactorily perform the work.

Bidders are notified that, in accordance with Division 2, Chapter 2 of the Torrance Municipal Code, the City Council may determine whether the Bidder is responsible based on a review of the Bidder's performance on other contracts.

If, based on the provision and criteria in Division 2, Chapter 2 of the Torrance Municipal Code, the General Services Director proposes not to recommend the award of contract to the apparent low bidder, the Director shall notify the Bidder in writing of its intention to recommend to the City Council that the Council award the contract to the next lowest responsible bidder. If the Bidder presents evidence in rebuttal to the recommendation, the Director shall evaluate the merits of such evidence, and based on that evaluation, make a recommendation to the City Council.

**C. ADDENDA TO THE CONTRACT DOCUMENTS**

The City reserves the right to revise or amend these specifications prior to the date set for opening bids. Revisions and amendments, if any, will be announced by an addendum to this bid. If the revisions require additional time to enable Bidders to

respond, the City may postpone the opening date accordingly. In such case, the addendum will include an announcement of the new opening date.

All addenda must be attached to the bid. Failure to attach any addendum may render the bid non-responsive and cause it to be rejected.

#### D. PREPARATION OF THE BID

##### 1. Examination of Site, Plans and Specifications

Bidders shall examine the site of the work and acquaint themselves with all conditions affecting the work. By submitting a bid, the bidder shall be held to have personally examined the site and the drawings, to have carefully read the specifications, and to have satisfied itself as to its ability to meet all the difficulties attending the execution of the proposed contract before the delivery of this proposal, and agrees that if awarded the contract, will make no claim against the City based on ignorance or misunderstanding of the plans, specifications, site conditions and/or contract provisions.

The Contractor shall have included in the contract price a sufficient sum to cover all items, including labor, materials, tools, equipment and incidentals, that are implied or required for the complete improvements as contemplated by the drawings, specifications, and other contract documents.

##### 2. Bid Instructions and Submissions

The Bid shall be submitted on the Bid Proposal forms included in the Specifications. All Bid Documents must be completed, executed and submitted with Bid by Bidder. Required seven (7) Bid Proposal Documents:

1. Bidder's Proposal
2. Addenda Acknowledgment
3. Contractor's Affidavit
4. Bid Bond (10% of Bid)
5. List of Subcontractors
6. References
7. Bidder's Information

All prices submitted will be considered as including any and all sales or use taxes. In case of a discrepancy between a unit bid price and total bid, the unit price shall prevail.

#### E. BID FORM/BOND

The Bid must be accompanied by cash, a certified or cashier's check, or a surety bond (bid bond) payable to the City of Torrance. Bids must be submitted on the proposal forms furnished by the City Clerk's office. The Bid Guaranty shall be in an amount equivalent to at least 10% of the Total Contract Bid Price.

Within ten (10) days after the award of the contract, the City Clerk will return the proposal guarantees accompanying those proposals, which are not to be considered in making

the award. All other proposal guarantees will be held until the contract has been finally executed, after which they will be returned to the respective bidders whose proposals they accompany.

F. AFFIDAVIT

An affidavit form is enclosed. It must be completed signifying that the bid is genuine and not collusive or made in the interest or on behalf of any person not named in the bid, that the bid has not directly or indirectly induced or solicited any other Bidder to put in a sham bid or any other person, firm, or corporation to refrain from bidding, and that the Bidder has not in any manner sought by collusion to secure for itself an advantage over any other Bidder. Any bid submitted without an affidavit or in violation of this requirement will be rejected.

G. NONRESPONSIVE BIDS AND BID REJECTION

1. A Bid in which bid proposal documents are not completed, executed and submitted may be considered non-responsive and be rejected.
2. A Bid in which the Contract Unit Prices are unbalanced, which is incomplete or which shows alteration of form or irregularities of any kind, or which contains any additions or conditional or alternate Bids that are not called for, may be considered non-responsive and be rejected.

H. AWARD OF CONTRACT

In accordance with Division 2, Chapter 2 of the Torrance Municipal Code, the City Council reserves the right to reject any and all bids received, to take all bids under advisement for a period not-to-exceed sixty (60) days after date of opening thereof, to waive any informality or irregularity in the Bid, and to be the sole judge of the merits of material included in the respective bids received.

This bid does not commit the City to award a contract or to pay any cost incurred in the preparation of a bid. All responses to this bid become the property of the City of Torrance.

I. NOTICE OF INTENT TO AWARD

Approximately two (2) weeks prior to the anticipated City Council meeting awarding a contract as a result of the RFP or bid, results will be posted on the City of Torrance Web site at <https://www.torranceca.gov/government/city-clerk/request-for-proposals>

J. BID PROTEST PROCEDURES

Please refer to City of Torrance website link below to obtain the City's Protest Procedures at <https://www.torranceca.gov/government/city-clerk/request-for-proposals>

K. EXECUTION OF CONTRACT

After the Contract is awarded, the awarded bidder shall execute the following five (5) documents:

1. Performance Bond (100% of Bid)
2. Labor and Material Bond (100% of Bid)
3. Contract – Contract Services Agreement
4. Verification of Insurance Coverage (Certificates and Endorsements)
5. Business License Application Form

The contract shall be signed by the successful bidder and returned, together with the contract bonds and evidence of required insurance coverage, **within ten (10) working days**, not including Sundays, after the bidder has received notice that the contract has been awarded. Failure to execute the contract as specified above shall be just cause for annulment of the award and forfeiture of the proposal guarantee. The Contract shall not be considered binding upon the CITY until executed by the authorized CITY officials.

Bond amounts shall be as provided in Section 2-4 of the Standard Specifications for Public Works Construction. The Performance Bond shall be required to remain in effect for one (1) year following the date specified in the City's Notice of Completion, or, if no Notice of Completion is recorded for one (1) year following the date of final acceptance by the City Manager.

L. PERMITS, LICENSES AND CONTRACT SERVICES AGREEMENT

The Contractor shall procure and execute all permits, licenses, pay all charges and fees, and give all notices necessary and incidental to completion of Work. The Contractor shall execute a Contract Services Agreement. No fee is charged for a permits issued by the City of Torrance for a City project. The Contractor shall obtain a City of Torrance Business License. To obtain a Torrance Business License please call 310-618-5923.

M. INSURANCE

The Contractor shall maintain Automobile Liability, General Liability and Workers' Compensation Insurance as specified in the Contract Services Agreement included in the Project Specifications.

N. SUBCONTRACTS

Each Bidder shall comply with the Chapter of the Public Contract Code including sections 4100 through 4114. The Contractor shall perform, with its own organization, Contract work amounting to at least 50 percent of the Contract price. When a portion of an item is subcontracted, the value of the work subcontracted will be based on the estimated percentage of the Contract Unit Price, determined from information submitted by the Contractor, subject to approval by the City Manager (or his designate representative). This percentage will be based on direct labor hours used on the project. Supervision and overhead are not included in this calculation.

O. TRAFFIC CONTROL- Not applicable

P. PRE-BID INQUIRIES

Bidders with pre-bid inquiries must submit questions in writing to the General Services Department. Any and all questions must be emailed to Nina Schroeder, Business Manager at [NSchroeder@TorranceCA.gov](mailto:NSchroeder@TorranceCA.gov). Please list “**Bid for City of Torrance Park Exterior Lighting Retrofit**” in the subject line of the email. **The deadline to submit questions is 12:00 p.m. Pacific Time on Wednesday, June 3, 2020.**

Q. RESPONSIBILITY OF CITY

The City of Torrance shall not be held responsible for the care or protection of any material or parts of the work prior to final acceptance, except as expressly provided in these specifications.

R. CONSTRUCTION SCHEDULE AND PRECONSTRUCTION CONFERENCE.

The office staff of the City is currently operating on a 9/80 work week; therefore, City Hall is closed every other Friday.

In accordance with the herein Special Provisions, after notification of award and prior to start of any work, **the Contractor shall submit to the City for approval its proposed Construction Schedule within ten (10) working days from the date of Notice to Proceed.** At least two (2) days, exclusive of Saturdays, Sundays and holidays, prior to commencement of work, the Contractor shall attend a pre-construction conference.

**The Contractor will provide all product and equipment submittals to the City of Torrance or designated consultant within ten (10) working days from the date of Notice to Proceed.** The Contractor shall immediately order materials requiring a delivery delay upon receipt of a written notice from the City that the City Council has approved an Award of Contract. Contractor shall provide written proof(s) of timely material order(s) and shall include any delivery delays in the Construction Schedule.

S. PROGRESS OF THE WORK AND TIME FOR COMPLETION

The Contractor shall begin work after the mailing, from the City Manager to the Contractor, by first class mail, postage prepaid, of a Notice to Proceed. **The Contractor shall diligently prosecute the same to completion within one hundred five (105) calendar days of the start date specified in said Notice.** The **one hundred five** calendar schedule includes, completion of contractual paper work, equipment material submittal review, the lead time for materials and equipment, and on site work.

During periods when weather or other conditions are unfavorable for construction, the Contractor shall pursue only such portions of the work as shall not be damaged thereby. No portions of the work whose acceptable quality or efficiency will be affected by any unfavorable conditions shall be constructed while those conditions exist. It is expressly understood and agreed by and between the Contractor and the City that the Contract time for completion of the work described herein is a reasonable time taking into consideration the average climatic and economic conditions and other factors prevailing in the locality of the work.



T. LIQUIDATED DAMAGES

The Contractor agrees that failure to complete work within the time allowed will result in damages being sustained by the City. Contractor and City agree that failure to complete the project will result in inconvenience to the citizens of Torrance and the City of Torrance and their customers using the affected areas. Such delay will also result in the necessity of several inspections each day to ensure that the project is properly progressing. The parties also agree that failure to complete the project on time will prevent the City from having the use of the facility. Therefore, the parties agree such damages among others are, and will continue to be, impracticable and extremely difficult to determine, but that **five hundred dollars (\$500) per calendar day** is the minimum value of such costs to the City and is a reasonable amount that the Contractor agrees to reimburse the City for each calendar day of delay in finishing the work in excess of the time specified for completion, plus any authorized time extensions.

Execution of the contract under these specifications shall constitute agreement by the Contractor and the City that five hundred dollars (\$500) per calendar day is the minimum value of the costs and actual damage caused by failure of the Contractor to complete the work within the allotted time, that such sum is liquidated damages and shall not be construed as a penalty, and that such sum may be deducted from payments due the Contractor if such delay occurs. Said amount may be reduced by the City if work is sufficiently completed within the allotted time so that the damages are minimized.

The Contractor will not be assessed liquidated damages for any delay in completion of the work when such delay was caused by the failure of the City or the owner of a utility to provide for removal or relocation of the existing utility facilities; provided, however, that the Contractor shall have given the City and the owner of a utility timely notice of the interference. "Timely notice" shall be defined as a verbal notice (to be followed up in writing) no later than one (1) hour after initial discovery of the interference unless the City Representative is present, in which case notice shall be given immediately in writing to the City Manager.

U. GENERAL PREVAILING WAGE RATE

This contract is subject to California State Prevailing Wage.

Pursuant to Section 1771 and 1773 of the Labor Code, the general prevailing wage rates in the county in which the work is to be done have been determined by the Director of the California Department of Industrial Relations. These wages are set forth in the General Prevailing Wage Rates for this project, are attached and available from the California Department of Industrial Relations' internet site at <http://www.dir.ca.gov/Public-Works/Prevailing-Wage.html>. Future effective general prevailing wage rates which have been predetermined and are on file with the California Department of Industrial Relations are referenced but not printed in the general prevailing wage rates.

APPRENTICESHIP EMPLOYMENT STANDARDS. Attention is directed to the provisions in Sections 1776 and 1777.5 of the California Labor Code concerning the employment of apprentices by the Contractor or any subcontractor under them.

One of the legal requirements for working on a public works project is the employment of apprentices. The Division of Apprenticeship Standards provides assistance to contractors in employing apprentices on public works sites.

Information relative to apprenticeship standards, wage schedules, and other requirements may be obtained from the Director of Industrial Relations, <http://www.dir.ca.gov/DAS/DASApprenticesOnPublicWorksSummaryOfRequirements.htm>

#### Contractor Registration with the Department of Industrial Relations (DIR)

- No contractor or subcontractor may be listed on a bid proposal or awarded a public works project unless registered with the Department of Industrial Relations pursuant to Labor Code section 1725.5 [with limited exceptions from this requirement for bid purposes only under Labor Code section 1771.1(a)].
- No contractor or subcontractor may be awarded a contract for public work on a public works project (awarded on or after April 1, 2015) unless registered with the Department of Industrial Relations pursuant to Labor Code section 1725.5.
- This project is subject to compliance monitoring and enforcement by the Department of Industrial Relations.
- All contractors and subcontractors must furnish electronic certified payroll records directly to the Labor Commissioner (aka Division of Labor Standards Enforcement).

For additional information and to register online go to <http://www.dir.ca.gov/Public-Works/Contractors.html>

DIR provides a searchable database of registered contractors and subcontractors on its website <http://efiling.dir.ca.gov/PWCR/Search>, so that all contractors can comply with the requirement to only use registered contractors and subcontractors.

#### Labor Code Section 1813

The contractor or subcontractor shall, as a penalty to the state or political subdivision on whose behalf the contract is made or awarded, forfeit twenty-five dollars (\$25) for each worker employed in the execution of the contract by the respective contractor or subcontractor for each calendar day during which the worker is required or permitted to work more than 8 hours in any one calendar day and 40 hours in any one calendar week in violations of the provisions of this article. In awarding any contract for public work, the awarding body shall cause to be inserted in the contract a stipulation to this effect. The awarding body shall take cognizance of all violations of this article committed in the course of the execution of the contract, and shall report them to the Division of Labor Standards Enforcement.

Labor Code Section 1815

Notwithstanding the provisions of Sections 1810 to 1814, inclusive, of this code and notwithstanding any stipulation inserted in any contract pursuant to the requirements of said sections, work performed by employees of contractors in excess of 8 hours per day, and 40 hours during any one week, shall be permitted upon public work upon compensation for all hours worked in excess of 8 hours per day than 1 ½ times the basic rate of pay.

V. PRELIMINARY NOTICES

Preliminary Notices should be mailed to the following address.

Nina Schroeder  
General Services Department  
3350 Civic Center Drive  
Torrance, CA 90503

**PART C**  
**SPECIAL PROVISIONS**

## **SECTION A. GENERAL**

The Project Specifications for all work on this project are the specifications contained in the **“Project Manual for City of Torrance Park Exterior Lighting Retrofit”** per plans and specifications provided by the City of Torrance.

Scope of work: The City of Torrance is seeking qualified contractors to upgrade its current exterior lighting at 17 park locations.

The contractor must purchase and install the equipment specified on the Bid Proposal in Section “D”. See also manufacturer specifications on Section “G”. The contractor must follow the installation procedures outlined by the fixture manufacturer. The contractor will ensure the installation meets these installation procedures so as to resolve any potential glare, wiring or other issues that reduce performance or void warranty of the product. All existing fixtures and associated components must be properly disposed to meet all federal, state and local requirements.

The Specifications in section G are intended to govern all aspects of the appurtenant construction including, but not limited to, materials, methods and details, except as modified herein or as inconsistent with the provisions hereof.

Scope of work must include all labor, equipment, materials and accessories for a complete and useable project acceptable to the City of Torrance.

The Specifications are included on the plans and are intended to govern all aspects of the appurtenant construction including, but not limited to, materials and details, except as modified herein or as inconsistent with the provisions hereof.

### **DEFINITIONS**

Whenever the following terms are used, they shall be understood to mean and refer to the following:

CITY - City of Torrance.

Board - The City Council of the City of Torrance herein referred to as City Council.

City Manager - The General Services Director of the City of Torrance, acting either directly or through properly authorized agents, such agents acting within the scope of the particular duties entrusted to them.

Laboratory - The designated laboratory authorized by the City of Torrance to test materials and work involved in the contract.

### **SECTION B. REFERENCE TO STANDARDS OR PUBLICATIONS**

Any reference made in the Contract Documents to any specification, standard, or publication of any organization shall, in the absence of a specific designation to the contrary, be understood to refer to the latest edition of the specification, standard, or publication in effect as of the date of advertising the work, except to the extent that said standard or publication may be in conflict with applicable laws, ordinances, or governing codes. Contractors should be aware of all new code

requirements (such as Cal-Green) when dealing with other general building work. No requirements of these specifications or the drawings shall be waived because of any provisions of, or omission from, said standards or publications.

### **SECTION C. DESCRIPTION OF THE WORK**

1. Scope of the Work. Scope of work must include all labor, equipment, materials and accessories for a complete and useable project acceptable to the City of Torrance and per project plans. Contractor is responsible to investigating existing site conditions, prior to submitting a bid.

### **SECTION D. GENERAL PROCEDURES**

1. Specifications and Drawings Complementary. The Drawings are complementary, and what is called for in one shall be as binding as if called for in both.
2. Order of Precedence of Contract Documents. In resolving conflicts resulting from conflicts, errors, or discrepancies in any of the Contract Documents, the order of precedence shall be as follows:
  1. Change Orders (including Plans and Specifications attached thereto).
  2. Permits Issued by other agencies
  3. Contract Services Agreement
  4. Addenda
  5. Special or General Provisions
  6. Plans
  7. City Standard Plans
  8. Instructions to Bidders
  9. Reference Specifications

Within the Specifications the order of precedence is as follows:

1. Addenda/Change Orders
2. Permits from other agencies/supplemental agreements
3. Special or General Provisions
4. Instructions to Bidders
5. Referenced Standard Plans
6. Referenced Specifications

With reference to the Plans/Drawings the order of precedence is as follows:

1. Change Orders plans govern over Addenda and Contract Drawings
  2. Addenda plans govern over Contract plans.
  3. Contract plans govern over standard plans
  4. Detail plans govern over general plans
  5. Figures govern over scaled dimensions
3. Discrepancies in the Contract Documents. Any discrepancies, conflicts, errors or omissions found in the Contract Documents shall be promptly reported in writing to the City Manager, who will issue a correction in writing. The Contractor shall not take advantage of any such discrepancies, conflicts, errors or omissions, but shall comply with

any corrective measures regarding the same prescribed by the City Manager, and no additional payment or time shall be allowed therefor.

If discrepancies are discovered between the drawings and the specifications, and no specific interpretation is issued prior to bidding, the decision regarding this interpretation shall rest with the City Manager. The Contractor shall be compelled to act on the City Manager's decision as directed. In the event the installation is not in compliance with the direction of the City Manager, the installation shall be corrected by and at the expense of the Contractor at no additional cost to the City.

See Section E of these Special Provisions for "Claims".

4. Errors and Omissions. If the Contractor, in the course of the work, becomes aware of any claimed errors or omissions in the contract documents or in the City's field work, he shall immediately inform the City Manager. The City Manager shall promptly review the matter, and if the City Manager finds an error or omission has been made the City Manager shall determine the corrective actions and advise the Contractor accordingly. If the corrective work associated with an error or omission increases or decreases the amount of work called for in the Contract, the City shall issue an appropriate Change Order. After discovery of an error or omission by the Contractor, any related work performed by the Contractor shall be done at its risk unless authorized by the City Manager.
5. Changed Conditions. The plans for the work show conditions as they are believed by the City Manager to exist, but it is not intended or to be inferred that the conditions as shown thereon constitute a representation by the City that such conditions are actually existent, nor shall the City be liable for any loss sustained by the Contractor as a result of any variance of the conditions as shown on the plans and the actual conditions revealed during the progress of the work or otherwise. The word "conditions" as used in this paragraph includes, but is not limited to, site conditions, both surface and subsurface.  
  
The Contractor shall examine the site, compare it with the drawings and specifications and shall satisfy itself as to the conditions under which the work is to be performed. The Contractor shall ascertain and check the location of all existing structures, utilities and equipment, which may affect its work. The Contractor shall be responsible to re-examine the site, as necessary, for performance of change orders or other proposed changes, which may affect its work. No allowance shall subsequently be made on the Contractor's behalf for any extra expense or loss of time, which is incurred due to failure or negligence on its part to make such examination.
6. As-built Drawings. The Contractor shall maintain a control set of Plans and Specifications on the Work site at all times. All final locations determined in the field, and any deviations from the Plans and Specifications, shall be marked in red on this control set to show as-built conditions. Upon completion of Work, the Contractor shall submit the control set to the Engineer for approval. Final payment will not be made until this requirement is met.
7. Construction Staking. The Contractor is responsible for all construction staking and shall be responsible for the cost of any restaking required due to disturbance caused by its operations, failure to protect the work site from vandalism or other causes of loss.

8. Notice to Proceed. Notwithstanding any other provisions of the Contract, the Contractor shall not be obligated to perform any work and the City shall not be obligated to accept or pay for any work performed by the Contractor prior to delivery of a Notice to Proceed. The City's knowledge of work being performed prior to delivery of the Notice to Proceed shall not obligate the City to accept or pay for such work. The Contractor shall provide all required contract bonds and evidences of insurance prior to commencing work at the site.
9. Delay in Obtaining Materials. No extension of time will be granted for a delay caused by the inability to obtain materials unless the Contractor either obtains advance written approval from the City Manager or obtains from the supplier and furnishes to the City Manager documentary proof that such materials could not be obtained due to war, government regulations, labor disputes, strikes, fires, floods, adverse weather necessitating the cessation of work, or other similar action of the elements. The Contractor is required to order materials in a timely manner as specified in the "Instruction to Bidders".
10. Inspection and Testing. The Work is subject to inspection and approval by the CITY or any authorized representative. It is the duty of the Contractor to notify the inspector that specific work is ready for inspection. Requests for inspections should be made through the automated phone system at 310-618-5901, using the permit number and following the prompts. Requests can be made up to 11pm the night before an inspection is required. The inspections will be typically made the next day.

All rough Mechanical, Electrical and Plumbing should be inspected by the City Specialty Inspectors and approved prior to any framing inspection. All framing, fire-blocking and bracing shall be in place prior to ordering a framing inspection. Gypsum board shall only be installed after approved framing inspection and then order a gypsum board nailing inspection prior to tape and finishing.

The CITY will make, or have made, such inspections and tests, as the City deems necessary to see that the Work is in conformance with the Contract Documents. The contractor will be responsible for coordinating the inspections and tests and pay for all related costs. In the event such inspections or tests reveal noncompliance with the Contract Documents, the Contractor shall bear the cost of such corrective measures as deemed necessary by the CITY, as well as the cost of subsequent re-inspection and re-testing.

Work done in the absence of inspection by the CITY may be required to be removed and replaced under the inspection of the CITY, and the entire cost of removal and replacement, including the cost of all materials which may be furnished by the CITY and used in the work thus removed, shall be borne by the Contractor, regardless of whether the work removed is found to be defective or not. Work covered without the approval of the CITY shall, if so directed, be uncovered to the extent required by the CITY, and the Contractor shall similarly bear the entire cost of performing all the work and furnishing all the materials necessary for the removal of the covering and its subsequent replacement, including all costs for additional inspection.

The CITY and any authorized representatives shall at all times have access to the Work during its construction at shops and yards as well as the Work site. The Contractor shall provide every reasonable facility for ascertaining that the materials and workmanship are in accordance with the Contract Documents.



Inspection of the Work shall not relieve the Contractor of the obligation to fulfill all conditions of the Contract.

11. Project Schedule

Within ten (10) working days after the receipt of the Notice to Proceed, the Contractor shall submit a proposed construction schedule to the CITY for approval. The schedule shall be in accordance with section 6 and shall be in sufficient detail to show chronological relationship of all activities of the Work. These include, but are not limited to: estimated starting and completion dates of various activities, submissions of submittals per 3.83 shop drawings, procurement of materials and scheduling of equipment.

No work may be started until the Schedule has been approved in writing. The work shall be scheduled to assure that construction will be completed within the specified time. The Contractor shall be responsible for coordination of all phases of the operation so that the time schedule can be met.

During construction, the Contractor shall also submit to the CITY, a two-week "look ahead" construction schedule during the construction progress meetings held biweekly. If the Contractor decides to make a major change in the method of operations after commencing construction, or if the schedule fails to reflect the actual progress, the Contractor shall submit to the CITY a revised construction schedule in advance of beginning revised operations.

Sequence of Construction - The Contractor shall sequence the Work in a manner to expeditiously complete the project with a minimum of inconvenience to the CITY or adjacent owners.

The construction schedule shall conform to the following criteria:

- 1) The schedule shall be prepared using the latest version of Microsoft Project or approved equal.
- 2) Work activities shall be based on the following:
  - a) Contract Unit Price items shall be subdivided into those portions to be constructed during each stage or phase of construction. (If applicable)
  - b) Lump sum items shall be subdivided into those portions to be constructed during each stage or phase of construction.
- 3) Utility relocations and/or coordination by the Contractor per section 14 of these Special Provisions shall be considered as activities.
- 4) Required submittals, working and shop drawings shall be included as activities.
- 5) The procurement of construction materials and equipment with long lead times for deliveries shall be included as activities.
- 6) Work to be performed by subcontractors shall be identified and shown as work activities.
- 7) Start and completion dates of each activity shall be illustrated.

- 8) Completion of all Work under the Contract shall be within the time specified in these Special Provisions and in accordance with the Plans and Specifications.

12. Mobilization

- 12.1 Scope. Mobilization shall include the provision of the Construction Schedule; Best Management Practices, Safety Plan, site review; obtaining all permits, insurance, and bonds; moving onto the site all materials and equipment; furnishing temporary construction facilities, and removal of same at completion of the project; all as required for the proper performance and completion of the work.

Mobilization shall include, but not be limited to, the following principle items.

- (a) Submittal and modification, as required, of the Construction Schedule.
- (b) All associated documentation and submittals as required.
- (c) Installing temporary construction power and wiring.
- (d) Establishing fire protection system.
- (e) Developing construction water supply.
- (f) Providing on-site sanitary facilities and portable water facilities, as required.
- (g) Arranging for and erection of Contractor's work and storage yard.
- (h) Submittal of all required insurance certificates and bonds, including subcontractors.
- (i) Obtaining all required permits.
- (j) Posting all OSHA required notices and establishment of safety programs.
- (k) Have the Contractor's superintendent at the job site full-time.
- (l) Pot-holing and other research and review as necessary to verify site conditions and utility locations, including research and review as necessary for change orders.
- (m) Demobilization.

13. Markup

The markups mentioned hereinafter shall include, but are not limited to, all costs for the services of superintendents, project managers, timekeepers and other personnel not working directly on the change order, and pickup or yard trucks used by the above personnel. These costs shall not be reported as labor and equipment elsewhere except when actually performing work directly on the change order and then shall be reported at the labor classification of the work performed.

The following percentages shall apply for additional work:

Profit	5% maximum
Overhead	10% maximum

Subcontractor markup: maximum allowed is 5% for profit and 10% for overhead on the subcontractor's costs.

To the sum of the costs and markups provided for in this subsection, one (1) percent shall be added as compensation for bonding and one (1) percent for insurance.

For changes involving only a decrease in price, the contractor and subcontractors shall return as credit for overhead and profit those same percentages which are allowed for like changes involving increase in price. On changes involving both an increase and decrease in price, overhead and profit will be allowed only on the net increase.

14. Utilities. The Contractor shall provide coordination with all the utility companies involved and shall provide protection from damage to their facilities. The Contractor shall be responsible for repair or replacement to said facilities made necessary by its failure to provide required protection. The Contractor is required to include utility requirements in the Construction Schedule.

The Contractor shall be solely responsible to check all utility record maps, books, and/or other data in the possession of the CITY, other agencies, and/or all utility companies, and no allowance shall be made for any failure to have done so.

The Contractor shall utilize the services of "Underground Service Alert - Southern California" for utility locating in all public right-of-ways by calling 1-800-227-2600 at least 48 hours prior to any excavation.

15. Completion, Acceptance, Warranty: If, in the CITY's judgment, the Work has been completed and is ready for acceptance, the CITY will so certify and will determine the date when the Work was completed. This will be the date when the Contractor is relieved from responsibility to protect the Work. The CITY may cause a Notice of Completion to be filed and recorded with the Los Angeles County Recorder's Office. At the CITY's option, the CITY may certify acceptance to the City Council who may then cause a Notice of Completion to be filed and recorded with the Los Angeles County Recorder's Office.

Manufacturer's warranties and guaranties furnished for materials used in the Work and instruction sheets and parts listed supplied with materials shall be delivered to the CITY prior to acceptance of the Work. The duration of the warranty or guaranty shall be the standard of the industry with a minimum of 1 year from the date of Notice of Completion or Date of Acceptance.

The prime contractor will be required to warranty the entire project regardless of whether warranties from subcontractors are also required. Coordination and correction of any issue related to project scope that arises during that one (1) year warranty period will be the responsibility of the prime contractor.

Manufacturer's warranties shall not relieve the Contractor of liability under these Specifications. Such warranties only shall supplement the Contractor's responsibility.

The CITY may require a manufacturer's warranty on any product offered for use.

16. Superintendent. Contractor shall employ a superintendent to be in attendance at all times on the Project site during the performance of the work. Superintendent shall represent the Contractor, and communications given to the superintendent shall be binding as if given to the Contractor. The superintendent must be able to communicate verbally and in writing to both City Representatives and all contract labor regarding all aspects of work. The superintendent shall be approved by the CITY prior to the start of the work. If the designated superintendent is rejected, the Contractor shall immediately designate another superintendent in writing and submit to the City for consideration. The CITY shall have the authority to require the Contractor to remove its superintendent and/or alternate superintendent at any time and at no cost to the CITY.

17. Requirements for Recycling Construction Materials

The City of Torrance requires that all demolition projects and construction or remodeling projects valued at \$100,000 or more must recycle or reuse at least 65% of the materials that leave the project site and 100% of excavated soil and land-clearing debris and any universal wastes. A Waste Management Plan (WMP) form is part of the permit process for projects that meet these criteria. The WMP form is available at the permit counter or a downloadable form is available here:

<https://www.torranceca.gov/our-city/public-works/residential-trash-and-recycling/construction-and-demolition-material-recycling>

Step 1 - when applying for the permit, you must complete the WMP form stating that at least 65% of the waste generated by the project will be recycled or reused and that 100% of excavated soil and land-clearing debris and universal wastes will be recycled or reused.

Step 2 - collect and keep all receipts and records of the disposal, recycling, donations, and reuse of the materials from your project. Receipts must show material type, tonnage or weight, how the materials were treated, the facility used, and the address of the jobsite.

Step 3 - complete the WMP by attaching the receipts listing the actual disposal and recycling that occurred and submitting the WMP to Public Works for approval. This is required before your project can get its final inspection.

***Failure to fulfill the requirements of the WMP process will result in penalties of \$5,000 for construction projects and \$10,000 for demolition projects, as per the Torrance Municipal Code.***

For additional information concerning recycling or recycling facilities please contact the City of Torrance Public Works Department website at (310) 781-6900.

## **SECTION E. PAYMENTS TO CONTRACTOR AND CLAIMS**

1. Breakdown of Contract Prices. The Contractor shall, within ten (10) working days of receipt of a request from the City, submit a complete breakdown of lump sum bid prices showing the value assigned to each part of the work, including an allowance for profit and overhead. The breakdown shall include separate line for each subcontractor's bid and/or contract amount. In submitting the breakdown, the Contractor certifies that it is not unbalanced and that the value assigned to each part of the work represents its estimate of the actual cost, including profit and overhead, of performing that part of the work. The breakdown shall be sufficiently detailed to permit its use by the City Manager as one of the bases for evaluating requests for payment. No extra costs shall be allowed for these breakdowns.
2. Payment for Labor and Materials. The Contractor shall pay and cause the subcontractors to pay any and all accounts for labor, including Worker's Compensation premiums, State Unemployment and Federal Social Security payments and all other wage and salary deductions required by law. The Contractor also shall pay and cause the subcontractors to pay any and all accounts for services, equipment and materials used by it and the subcontractors during the performance of work under this contract. All such accounts shall be paid as they become due and payable. If requested by the City Manager, the Contractor shall immediately furnish the City with proof of payment of such accounts.
3. Additional Work. Payment for additional work and all expenditures in excess of the bid amount must be authorized in writing by the City Manager. Such authorization shall be obtained by the Contractor prior to engaging in additional work. It shall be the Contractor's sole responsibility to obtain written approval from the City Manager for any change(s) in material or in the work proposed by suppliers or subcontractors. No payment shall be made to the Contractor for additional work which has not been approved in writing, and the Contractor hereby agrees that it shall have no right to additional compensation for any work not so authorized.
4. Claims. The Contractor shall not be entitled to the payment of any additional compensation for any cause, including any act, or failure to act, by the City, or the happening of any event, thing or occurrence, unless he shall have given the City due written notice of potential claim as hereinafter specified.

The written notice of potential claim shall set forth the reasons for which the Contractor believes additional compensation will or may be due, the nature of the costs involved, and, insofar as possible, the amount of the potential claim. Said notice shall be submitted on a form approved by the City at least forty-eight (48) hours (two working days) in advance of performing said work, unless the work is of an emergency nature, in which case the Contractor shall notify and obtain approval from the Inspector prior to commencing the work. The City Manager may require the Contractor to delay construction involving the claim, but no other work shall be delayed, and the Contractor shall not be allowed additional costs for any said delay but may be allowed on extension of time if the City Manager agrees that the work delayed is a controlling element of the Construction Schedule. The Contractor shall be required to submit any supporting data (or a detailed written explanation justifying further delay) within five (5) Work Days of a request from the City Manager and shall be responsible for any delays resulting from late and/or incomplete submittals. By submitting a Bid, the Contractor hereby agrees that this Section shall supersede Sections 6-4.3 and 6-4.4 of the Standard Specifications.

The City shall be the sole authority to interpret all plans, specifications and contract documents, and no claim shall be accepted which is based on the Contractor's ignorance, misunderstanding or noncompliance with any provision or portion thereof.

The Contractor shall be responsible to provide all data and to obtain all approvals required by said Specifications. No claims or extras shall be approved by the City unless all work was done under the direction of and subject to the approval of the Inspector.

It is the intention of this Subsection that differences between the parties arising under and by virtue of the Contract be brought to the attention of the City Manager at the earliest possible time in order that such matters may be settled, if possible, or other appropriate action promptly taken. The Contractor hereby agrees that it shall have no right to additional compensation for any claim that may be based on any such act, failure to act, event, thing or occurrence for which no written notice of potential claim as herein required was filed.

5. Noncompliance with Plans and Specifications. Failure of the Contractor to comply with any requirement of the Plans and Specifications, and/or to immediately remedy any such noncompliance upon notice from the City Manager, may result in suspension of Contract Progress Payments. Any Progress Payments so suspended shall remain in suspension until the Contractor's operations and/or submittals are brought into compliance to the satisfaction of the City Manager. No additional compensation shall be allowed as a result of suspension of Progress Payments due to noncompliance with the plans or specifications. The Contractor shall not be permitted to stop work due to said suspension of Progress Payments.
6. Request for Payment. Contractor shall submit all requests for payment on AIA Document G702 – Application and Certificate for Payment and G703- Continuation Sheet. For each item provide a column for listing: Item Number; Description of Work; Scheduled Value, Previous Application; Authorized Change Orders; Total completed and Stored to Date of Application; Percentage of Completion; Balance to Finish; and Retainage.

Prior to submittal of said form, all items for which payment is requested shall be checked and approved in writing by the City Manager. No payments will be made unless all back-up data is submitted with the payment request and the Progress Payment Invoice is signed by both Contractor and Manager.

Back up data required to process payment shall include but not limited to the following:

- Copies of Certified payroll covering the payment period and proof of submission to the Department of Industrial Relations (DIR). Although this project is subject to compliance monitoring and enforcement by the DIR. The City reserves the right to review the certified payroll for compliance, request additional clarification and require the contractor to provide proof of payment such as cancelled checks prior to payment of invoice.
- Conditional and Unconditional lien releases from contractor, subcontractor and suppliers from which the contractor is expecting payment. Release forms must reflect amount of draw and through date of invoice payment.
  1. Conditional releases for the current pay period shall be provided with the current payment request.
  2. Unconditional releases for the immediate prior pay period shall be provided with the current payment request. Unconditional lien release forms must match the preceding Conditional release form in amount and through date and must be signed authorized company representative. Unconditional Lien Release on Final Payment with a zero balance is required from all material suppliers and subcontractors with the request for final payment (retention). All Unconditional Lien Release on Final Payments will be signed authorized company representative and notarized. Release forms can be found at the Contractors State License Board website at [https://www.cslb.ca.gov/Consumers/Legal\\_Issues\\_For\\_Consumers/Mechanics\\_Lien/Conditional\\_And\\_Unconditional\\_Waiver\\_Release\\_Form.aspx](https://www.cslb.ca.gov/Consumers/Legal_Issues_For_Consumers/Mechanics_Lien/Conditional_And_Unconditional_Waiver_Release_Form.aspx). The most update current lien release forms must be used.
- Any required outside agency reports and/or written observations.

The City will retain 5 percent of the value of all work done and materials installed as part security for fulfillment of the contract by Contractor. The full 5 percent retention will be retained on all payments for 35 days after the filing of the Notice of Completion. In addition 125% of the amount of the “unreleased” STOP notice will be withheld.

There shall be no separate payment for any relocations, barriers or forms, grading or temporary construction required to construct the improvements herein. Payment for these items shall be absorbed in the Bid Prices for the applicable work to which they are appurtenant, and no extra costs shall be allowed.

The payment of amounts due to the Contractor shall be contingent upon the Contractor furnishing the City with a release of all claims against the City arising by virtue of the Contract related to said amounts. It is the contractor’s responsibility to provide the correct releases in order to obtain payment by the City.

7. Preconstruction Meeting. The City will hold a preconstruction meeting with awarded contractor and discuss procedural, and mobilization issues. The contractor needs to have key administrative staff attend such as: project manager, superintendent, administrative personnel who handle the certified payroll and pay requests. Attendees can also include subcontractors and major suppliers/fabricators.

In addition to staffing preconstruction meeting, the awarded contractor will need to bring the following to the preconstruction meeting for review and discussion.

- Project Schedule (see Special Provisions section D General Procedures #10 for details)
- Schedule of Values (see Special Provisions section E, Payment to Contractors #1 for details)
- Submittal Log, list all the submittals you plan to submit for review.
- List of subcontractors and contact information
- Prime Contractor's Safety Plan
- Example of Daily Project Report and Daily Sign In Sheet for Review (see #8 below for details)
- Prime contractors' signed contract, performance and labor and material bonds, insurance certificates with endorsements, workers compensation certificate and Torrance Business License. The exact verbiage of additionally insured clause for the insurance is found Item 18 of the contract. The certificate needs to be endorsed as well naming the City as additional insured.
- Signed contracts for subcontractors, insurance certificates with endorsements, workers compensation certificates. Subcontractor's insurance must also meet the contract limits and language and be endorsed.

8. Daily Project Report and Contractor Daily Sign In Sheets.

The contractor will provide daily project reports and/or contractor daily sign in sheets on a daily basis (next working day) during the entire project's onsite work. At minimum the report/sign in sheets consist of the following:

#### Daily Project Report

- Date, Day of the Week, and Weather
- List all staffing by prime and subcontractors each, include classification and count of persons within the specific classification and denote journeyman vs. apprentice.
- List all deliveries of equipment and materials to site.
- List onsite discussions, meetings any resolution or direction given.
- List progress of the project (i.e. was scheduled and completed).
- List all visitors to the site.

#### Daily Sign In Sheet

- Date and Day of the Week
- Employee Name (printed), company and classification of work, denote journeyman vs. apprentice for each classification.
- Time started and time completed, any breaks.
- Employee signature of the individual worker (confirming reported time)



**PART D**  
**BID DOCUMENTS**

**BIDDER'S PROPOSAL**

**BID FOR CITY OF TORRANCE PARK EXTERIOR LIGHTING RETROFIT  
B2020-13**

In accordance with the Notice Inviting Bids pertaining to the receiving of sealed proposals by the City Clerk of the City of Torrance for the above titled improvement, the undersigned hereby proposes to furnish all work to be performed in accordance with the Contract Documents, prepared by the City of Torrance for the bid as set forth in the following schedules.

Assignment of Contractor's values:

<b>Item</b>	<b>Park Location</b>	<b># Units</b>	<b>Existing Fixture/Lamp Type</b>	<b>Proposed Fixture Manufacturer/Catalog #</b>	<b>Total Amount In Figures</b>
01	<b>Delthorne Park</b> - 3401 Spencer St, Torrance 90503	31	(1) Wallpack – HPS70 (4) Surface mount - MH 175 (4) Flood double fixture – MH 400 (4) Flood double fixture – MH 250 (3) Flood triple fixture – MH 250 (1) Flood – MH 250 (14) Shoebox – MH 250	(1) ATG Electronics / WPDS-28-40-G3 (4) RAB / VANLED40 (4) ATG Electronics / AS15-40-T3-7PIN MSF-AS-00 (22) MESTER / 27V40KDT3/ SPAL04DA /JL-241C-Kit	\$
02	<b>Discovery Park</b> - 22526 Ocean Ave, Torrance, CA 90505	7	(1) Surface mount – MH 175 (6) Post-top – MH 175	(1) RAB / VANLED40 (6) RAB / LED5T78N/480	\$
03	<b>El Nido Park</b> - 18301 Kingsdale Ave, Redondo Beach, CA 90278	10	(10) Area lighter – MH 250	(10) MESTER / 27V40KDT3/ SPAL04DA /JL- 241C-Kit	\$
04	<b>El Retiro Park</b> - 126 Vista Del Parque, Redondo Beach, CA 90277	42	(20) Wallpacks – MH 175 (1) Surface mount – MH 175 (20) Flood – MH 400 (1) Pumpkin head – HPS 200	(20) ATG Electronics / WPDS-60-40-G3 (1) RAB / VANLED40 (20) ATG Electronics - AS15-40-V-T3-7PIN MSF-AS-00 (1) RAB / LED5T78N/480	\$
05	<b>Hickory Park</b> - 2850 W 232nd St, Torrance, CA 90505	8	(2) Surface mount – MH 175 (6) Shoebox – MH 1000	(2) RAB / VANLED40 (6) ATG Electronics - AS30-40-V-T3-7PIN MAM-AS-0S	\$
06	<b>La Carretara Park</b> - 2040 186th St, Torrance, CA 90504	9	(4) Flood – MH 400 (2) Flood – MH 250 (3) Shoebox – MH 250	(4) ATG Electronics - AS15-40-V-T3-7PIN MSF-AS-00 (5) MESTER / 27V40KDT3/ SPAL04DA /JL-241C-Kit	\$
07	<b>La Romeria Park</b> - 19501 S Inglewood Ave, Torrance, CA 90503	18	(3) Flood – MH175 (12) Flood – MH 1000 (3) Surface mount – MH 175	(15) MESTER / 27V40KDT3/ SPAL04DA /JL-241C-Kit (3) RAB / VANLED40	\$
08	<b>Lago Seco Park</b> - 3920 W 235th St, Torrance, CA 90505	3	(2) Wallpack – MH 250 (1) Wallpack – MH 175	(3) ATG Electronics / WPDS-60-40-G3	\$

**BIDDER'S PROPOSAL – Continued**

Item	Park Location	# Units	Existing Fixture/Lamp Type	Proposed Fixture Manufacturer/Catalog #	Total Amount In Figures
09	<b>Osage Park</b> - 17002 Osage Ave, Torrance, CA 90504	2	(2) Flood – MH 250	(2) MESTER / 27V40KDT3/ SPAL04DA /JL-241C-Kit	\$
10	<b>Paradise Park</b> - 5006 Lee St, Torrance, CA 90503	19	(3) Surface mount – MH 175 (16) Shoebox – MH 1000	(3) RAB / VANLED40 (16) ATG Electronics - AS30-40-V-T3-7PIN MAM-AS-0S	\$
11	<b>Pequeno Park</b> - 180th St & Regina Ave, Torrance, CA 90504	2	(1) Pumpkin head – MH 150 (1) Area lighter – HPS 200	(1) RAB / LED5T78N/480 (1) 27V40KDT3/ SPAL04DA /JL-241C-Kit	\$
12	<b>Pueblo Park</b> - 2252 Del Amo Blvd Torrance, CA 90501	11	(8) Surface mount – MH 50 (1) Flood – MH 175 (2) Flood – MH 400	(8) RAB / VANLED40 (1) MESTER / 27V40KDT3/ SPAL04DA /JL-241C-Kit (1) ATG Electronics - AS15-40-V-T3-7PIN MSF-AS-00	\$
13	<b>Sea-Aire Park</b> - 22730 Lupine Dr, Torrance 90505	5	(3) Flood – HPS 400 (2) Wallpacks – MH 70	(3) ATG Electronics - AS15-40-V-T3-7PIN MSF-AS-00 (2) ATG Electronics / WPDS-28-40-G3	\$
14	<b>Sunnyglen Park</b> - 5525 Del Amo Blvd, Torrance, CA 90503	13	(3) Shoebox – MH 250 (10) Pumpkin heads – HPS 200	(3) MESTER / 27V40KDT3/ SQAL04DA /JL-241C-Kit (10) RAB / LED5T78N/480	\$
15	<b>Sur La Brea Park</b> - 1951 W 237th St, Torrance 90501	42	(25) Flood – MH 400 (2) Wallpacks – MH175 (15) Pumpkin heads – HPS 200	(25) ATG Electronics - AS15-40-V-T3-7PIN MSF-AS-00 (2) ATG Electronics / WPDS-60-40-G3 (15) RAB / LED5T78N/480	\$
16	<b>Victor Park</b> - 4727 Emerald St, Torrance, CA 90503	15	(1) Wallpack – MH 175 (2) Wallpack – MH 250 (12) Pumpkin head – HPS 200	(3) ATG Electronics / WPDS-60-40-G3	\$
17	<b>Walteria Park</b> - 3855 W 242nd St, Torrance, CA 90505	12	(4) Flood – MH 400 (4) Surface mount – MH 175 (4) Wallpack – MH 175	(4) ATG Electronics - AS15-40-V-T3-7PIN MSF-AS-00 (4) RAB / VANLED40 (4) ATG Electronics / WPDS-60-40-G3	\$
<b>B2020-13 – BID TOTAL – in figures*</b>				\$	

**Bidders Proposal – B2020-13**

**BASE BID TOTAL:** \_\_\_\_\_

(In Words)\*

**BIDDER'S PROPOSAL – Continued**

**Bidders may bid on all or part of these requirements as indicated on the price proposal. The City may award one or more contracts for these items to the lowest responsible bidder of each item or group of items. The City may award to one vendor if doing so is in the best interest of the City.**

**\*BID MAY BE REJECTED IF TOTAL IS NOT SHOWN IN FIGURES AND WORDS.**

The City of Torrance awards to the lowest responsible bidder per the Torrance Municipal Code. Based on the funding available, the City reserves the right to select any combination of roofs to proceed with replacement to determine the lowest responsible bidder for award.

The undersigned furthermore agrees to enter into and execute a contract, with necessary bonds, at the prices set forth herein and in case of default in executing such contract, with necessary bonds, the check or bond accompanying this bid and the money payable thereon shall be forfeited thereby to and remain the property of the City of Torrance.

The above prices include all work appurtenant to the various items as outlined in the project plans and specifications and all work or expense required for the satisfactory completion of said item.

The undersigned declares that it has carefully examined the Specifications, Plans and Contract Documents, and has investigated the site of the work and is familiar with the conditions thereon.

\_\_\_\_\_  
Company Name

\_\_\_\_\_  
Signature of principal in company

\_\_\_\_\_  
Date

\_\_\_\_\_  
Name and Title of Signer

Address: \_\_\_\_\_ Phone: \_\_\_\_\_

Fax: \_\_\_\_\_ Email: \_\_\_\_\_

Public Works Registration (PWCR) Number: \_\_\_\_\_

License No. & Classifications \_\_\_\_\_

**ACKNOWLEDGMENT OF ADDENDA RECEIVED**

B2020-13

The Bidder shall acknowledge the receipt of addenda by placing an "X" by each addendum received.

Addendum No. 1 \_\_\_\_\_

Addendum No. 2 \_\_\_\_\_

Addendum No. 3 \_\_\_\_\_

Addendum No. 4 \_\_\_\_\_

Addendum No. 5 \_\_\_\_\_

Addendum No. 6 \_\_\_\_\_

Addendum No. 7 \_\_\_\_\_

Addendum No. 8 \_\_\_\_\_

If an addendum or addenda have been issued by the City and not noted above as being received by the Bidder, the Bid Proposal may be rejected.

\_\_\_\_\_  
Bidder's Signature

\_\_\_\_\_  
Date



**CONTRACTOR'S AFFIDAVIT B2020-13 (CONTINUED)**

7. That the Contractor did not, directly or indirectly, submit the Contractor's bid price or any breakdown thereof, or the contents thereof, or divulge information or data relative thereto, to any corporation, partnership, company, association, organization, bid depository, or to any member or agent thereof, or to any individual or group of Individuals, except to the City of Torrance, or to any person or persons who have a partnership or other financial interest with said Contractor in its business.

Dated this \_\_\_\_\_ day of \_\_\_\_\_, 20\_\_\_\_\_.

Subscribed and Sworn to \_\_\_\_\_ before me this \_\_\_\_\_  
(Contractor)

of \_\_\_\_\_, 20\_\_\_\_\_ \_\_\_\_\_  
(Title)

\_\_\_\_\_  
(Seal) Notary Public in and for said County and State.

NOT FOR PRINT

**BID BOND**

B2020-13

**KNOW ALL MEN BY THESE PRESENTS:** That we, \_\_\_\_\_

as principal, and \_\_\_\_\_  
as sureties, are held and firmly bound unto the City of Torrance, State of California, in the penal sum of \_\_\_\_\_ dollars (\$\_\_\_\_\_), for the payment whereof we hereby bind ourselves, our successors, heirs, executors or administrators jointly and severally, firmly by these presents.

The condition of this obligation is such that, whereas the above bounded principal is about to file with and submit to the City of Torrance a bid or proposal for the performance of certain work as required in the City of Torrance, Project No. **B2020-13**, said work being: **CITY OF TORRANCE PARK EXTERIOR LIGHTING RETROFIT** in compliance with the Plans therefore under an invitation of said City contained in a notice or advertisement for bids or proposals; now if the bid or proposal of said principal shall be accepted and if said work be thereupon awarded to the principal by said City and if the said principal shall enter into a contract with the said City in accordance with said bid or proposal, or if the bid or proposal of the said principal is rejected, then this bond shall be void and of no effect and otherwise in full force and effect.

**WITNESS** our hands this \_\_\_\_\_ day of \_\_\_\_\_, 20 \_\_\_\_\_.

\_\_\_\_\_  
Principal

\_\_\_\_\_  
Surety/Attorney-in-Fact

\_\_\_\_\_  
Signature

Name: \_\_\_\_\_

Local Address: \_\_\_\_\_

\_\_\_\_\_

Phone No.: \_\_\_\_\_

Fax No.: \_\_\_\_\_



**LIST OF SUBCONTRACTORS**

The Bidder is required to fill in the following blanks in accordance with the provisions of the Subletting and Subcontracting Fair Practices Act (Chapter 2 of Division 5, Title 1 of the Government Code of the State of California) and should familiarize itself with Section 2-3 of the Standard Specifications.

1. Name Under Which Subcontractor is Licensed: \_\_\_\_\_

Subcontractor's Address: \_\_\_\_\_

Specific Description of Sub-Contract: \_\_\_\_\_

License Number: \_\_\_\_\_ CA License Classification/Type: \_\_\_\_\_

Public Works Registration (PWCR) Number: \_\_\_\_\_

2. Name Under Which Subcontractor is Licensed: \_\_\_\_\_

Subcontractor's Address: \_\_\_\_\_

Specific Description of Sub-Contract: \_\_\_\_\_

License Number: \_\_\_\_\_ CA License Classification/Type: \_\_\_\_\_

Public Works Registration (PWCR) Number: \_\_\_\_\_

3. Name Under Which Subcontractor is Licensed: \_\_\_\_\_

Subcontractor's Address: \_\_\_\_\_

Specific Description of Sub-Contract: \_\_\_\_\_

License Number: \_\_\_\_\_ CA License Classification/Type: \_\_\_\_\_

Public Works Registration (PWCR) Number: \_\_\_\_\_

4. Name Under Which Subcontractor is Licensed: \_\_\_\_\_

Subcontractor's Address: \_\_\_\_\_

Specific Description of Sub-Contract: \_\_\_\_\_

License Number: \_\_\_\_\_ CA License Classification/Type: \_\_\_\_\_

Public Works Registration (PWCR) Number: \_\_\_\_\_

5. Name Under Which Subcontractor is Licensed: \_\_\_\_\_

Subcontractor's Address: \_\_\_\_\_

Specific Description of Sub-Contract: \_\_\_\_\_

License Number: \_\_\_\_\_ CA License Classification/Type: \_\_\_\_\_

Public Works Registration (PWCR) Number: \_\_\_\_\_

6. Name Under Which Subcontractor is Licensed: \_\_\_\_\_

Subcontractor's Address: \_\_\_\_\_

Specific Description of Sub-Contract: \_\_\_\_\_

License Number: \_\_\_\_\_ CA License Classification/Type: \_\_\_\_\_

Public Works Registration (PWCR) Number: \_\_\_\_\_

7. Name Under Which Subcontractor is Licensed: \_\_\_\_\_

Subcontractor's Address: \_\_\_\_\_

Specific Description of Sub-Contract: \_\_\_\_\_

License Number: \_\_\_\_\_ CA License Classification/Type: \_\_\_\_\_

Public Works Registration (PWCR) Number: \_\_\_\_\_

Subcontractors must be properly licensed under the laws of the State of California for the type of work which they are to perform. Do not list alternate subcontractors for the same work.

The Bidding Contractor must include each subcontractor's contract license number (AB 44). An inadvertent error in listing the subcontractor's license number shall not be grounds for filing a bid protest or grounds for considering the bid nonresponsive, if the corrected contractor's license number is submitted to the public entity by the prime contractor within 24 hours after the bid opening-provided that the correct license number corresponds to the submitted name and location of the subcontractor.

No contractor or subcontractor may be listed on a bid proposal for a public works project unless registered with the Department of Industrial Relations pursuant to Labor Code section 1725.5 [with limited exceptions from this requirement for bid purposes only under Labor Code section 1771.1 (a)].

No contractor or subcontractor may be awarded a contract for public work on a public works project unless registered with the Department of Industrial Relations pursuant to Labor Code section 1725.5.

**REFERENCES**

Bidder must have completed at least three (3) public works projects of a similar size and scope within the last five (5) years. The references must reflect this requirement. ***Do not list a reference more than once or include the City of Torrance as a reference.***

1	Name of Firm/Agency:	
	Street Address:	
	City: State, Zip Code:	
	Name of Person to Contact:	
	Phone Number of Contact:	
	Email Address of Contact:	
	Title of Project:	
	Project Location:	
	Date of Completion:	
	Contract Amount:	
2	Name of Firm/Agency:	
	Street Address:	
	City: State, Zip Code:	
	Name of Person to Contact:	
	Phone Number of Contact:	
	Email Address of Contact:	
	Title of Project:	
	Project Location:	
	Date of Completion:	
	Contract Amount:	
3	Name of Firm/Agency:	
	Street Address:	
	City: State, Zip Code:	
	Name of Person to Contact:	
	Phone Number of Contact:	
	Email Address of Contact:	
	Title of Project:	
	Project Location:	
	Date of Completion:	
	Contract Amount:	

Contractor's License No.: \_\_\_\_\_ Class: \_\_\_\_\_

Contractor's Public Works Registration (PWCR) Number: \_\_\_\_\_

Date first obtained: \_\_\_\_\_

Has License ever been suspended or revoked? \_\_\_\_\_

If yes, describe when and why \_\_\_\_\_

Any current claims against License or Bond? \_\_\_\_\_

If yes, describe claims: \_\_\_\_\_

Type of entity (check one)

\_\_\_\_\_ Incorporated \_\_\_\_\_ Partnership \_\_\_\_\_ Sole Proprietorship

If incorporated, in what state \_\_\_\_\_

Federal Tax ID Number # \_\_\_\_\_

Principals in Company (List all - attach additional sheets if necessary):

<u>NAME</u>	<u>TITLE</u>	<u>LICENSE NO.</u> (If Applicable)
_____	_____	_____
_____	_____	_____
_____	_____	_____
_____	_____	_____
_____	_____	_____
_____	_____	_____
_____	_____	_____
_____	_____	_____
_____	_____	_____

**Bidder's Information**

The bidder must provide a detailed list of the trades and the description of the work they will perform with their own company for this project.

1. \_\_\_\_\_
2. \_\_\_\_\_
3. \_\_\_\_\_
4. \_\_\_\_\_
5. \_\_\_\_\_
6. \_\_\_\_\_
7. \_\_\_\_\_
8. \_\_\_\_\_
9. \_\_\_\_\_
10. \_\_\_\_\_
11. \_\_\_\_\_
12. \_\_\_\_\_
13. \_\_\_\_\_
14. \_\_\_\_\_
15. \_\_\_\_\_

NOT FOR PRINT

**PART E**

**DOCUMENTS TO BE COMPLETED  
AND DELIVERED TO CITY AS PART  
OF CONTRACT WITH THE CITY**

**PERFORMANCE BOND**

**KNOW ALL MEN BY THESE PRESENTS:**

That we, \_\_\_\_\_ as Principal(s) and \_\_\_\_ a \_\_\_\_\_ corporation, incorporated, organized, and existing under the laws of the State of \_\_\_\_\_, and authorized to execute bonds and undertakings and to do a general surety business in the State of California, as Surety, are jointly and severally held and firmly bound unto the City of Torrance, a municipal corporation, located in the County of Los Angeles, State of California, in the full and just sum of: \_\_\_\_\_ Dollars (\$ \_\_\_\_\_), lawful money of the United States of America, for the payment of which sum, well and truly to be made, we bind ourselves and our respective heirs, executors, administrators, representative, successors and assigns, jointly and severally, firmly by these presents.

**THE CONDITION OF THIS OBLIGATION IS SUCH**, that: WHEREAS, said Principal(s) have/has entered into, or are/is about to enter into, a certain written contract or agreement, dated as of the \_\_\_\_\_ day of \_\_\_\_\_, 20\_\_\_\_, with the said City of Torrance for the **CITY OF TORRANCE PARK EXTERIOR LIGHTING RETROFIT, B2020-13**, all as is more specifically set forth in said contract or agreement, a full, true and correct copy of which is hereunto attached, and hereby referred to and by this reference incorporated herein and made a part hereof;

**NOW, THEREFORE**, if the said Principal(s) shall faithfully and well and truly do, perform and complete, or cause to be done, performed and complete, each and all of the covenants, terms, conditions, requirements, obligations, acts and things, to be met, done or performed by said Principal(s), including any guarantee period as set forth in, or required by, said contract or agreement, all at and within the time or times, and in the manner as therein specified and contemplated, then this bond and obligation shall be null and void; otherwise it shall be and remain in full force, virtue and effect.

The said Surety, for value received, hereby stipulates and agrees that no amendment, change, extension of time, alteration or addition to said contract or agreement, or of any feature or item or items of performance required therein or there under, shall in any manner affect its obligations on or under this bond; and said Surety does hereby waive notice of any such amendment, change, extension of time, alteration, or addition to said contract or agreement, and of any feature or item or items of performance required therein or there under.

**PERFORMANCE BOND B2020-13 (CONTINUED)**

In the event any suit, action or proceedings is instituted to recover on this bond or obligation, said Surety will pay, and does hereby agree to pay, as attorney's fees for said City, such sum as the Court in any such suit, action or proceeding may adjudge reasonable.

**EXECUTED, SEALED AND DATED** this \_\_\_\_\_ day of \_\_\_\_\_, 20\_\_\_\_

CORPORATE SEAL

PRINCIPAL(S):

BY \_\_\_\_\_

BY \_\_\_\_\_

CORPORATE SEAL

SURETY:

BY \_\_\_\_\_

Name: \_\_\_\_\_

Local Address: \_\_\_\_\_

\_\_\_\_\_

Phone No.: \_\_\_\_\_

Fax No.: \_\_\_\_\_



**LABOR AND MATERIAL BOND**  
B2020-13

**KNOW ALL MEN BY THESE PRESENTS:**

That we, \_\_\_\_\_  
As Principal(s) and \_\_\_\_\_ a  
corporation, incorporated, organized, and existing under the laws of the State of  
\_\_\_\_\_, and authorized to execute bonds and undertakings and to do a general surety  
business in the State of California, as Surety, are jointly and severally held and firmly bound unto:

- (a) The State of California for the use and benefit of the State Treasurer, as ex-officio Treasurer and custodian of the Unemployment Fund of said State; and
- (b) The City of Torrance, California; and
- (c) Any and all persons who do or perform or who did or performed work or labor upon or in connection with the work or improvement referred to in the contract or agreement hereinafter mentioned; and
- (d) Any and all materialmen, persons, companies, firms, association, or corporations, supplying or furnishing any materials, provisions, provender, transportation, appliances or power, or other supplies used in, upon, for or about or in connection with the performance of the work or improvement contracted to be executed, done, made or performed under said contract or agreement; and
- (e) Any and all persons, companies, firms, associations, or corporations furnishing, renting, or hiring teams, equipment, implements or machinery for, in connection with, or contributing to, said work to be done or improvement to be made under said contract or agreement; and
- (f) Any and all persons, companies, firms, associations, or corporations who supply both work and materials;

and whose claim has not been paid by said Principal(s), in full and just sum of \_\_\_\_\_ Dollars (\$\_\_\_\_\_), lawful money of the United States of America, for the payment of which will and truly to be made, said Principal(s) and said Surety do hereby bind themselves and their respective heirs, executors, administrators, representatives, successors and assigns, jointly and severally, firmly by these presents.

**LABOR AND MATERIAL BOND (CONTINUED)**

**THE CONDITION OF THE FOREGOING OBLIGATION IS SUCH, THAT: WHEREAS,** said Principal(s) have/has entered into or are/is about to enter into a certain written contract or agreement, dated as of the \_\_\_\_\_ day of \_\_\_\_\_ 20 \_\_\_\_, with the City of Torrance for the **CITY OF TORRANCE PARK EXTERIOR LIGHTING RETROFIT; B2020-13**, all as is more specifically set forth in said contract or agreement, a full, true and correct copy of which is hereunto attached, and hereby referred to and by this reference incorporated herein and made a part hereof;

**NOW, THEREFORE,** if the said Principal(s) (or any of his/her, its, or their subcontractors) under said contract or agreement fails or fail to pay:

- (1) For any materials, provisions, provender, transportation, appliances, or power, or other supplies; or
- (2) For the hire of any teams, equipment, implements, or machinery; or
- (3) For any work or labor; supplies, furnished, provided, used, done or performed in, upon, for or about or in connection with the said work or improvement; or
- (4) For amounts due under the Unemployment Insurance Act of the State of California with respect to such work or improvement;

the Surety on this bond will pay the same in an amount not exceeding the sum hereinabove specified in this bond; and, also, in case suit is brought upon this bond, said Surety will (and does hereby agree to) pay a reasonable attorney's fee, to be fixed and taxed as costs, and included in the judgment therein rendered.

This bond shall (and it is hereby made to) insure to the benefit of any and all persons entitled to file claims under Section 1192.1 of the Code of Civil Procedure of the State of California, so as to give a right of action to them or their assigns in any suit brought upon this bond, all as contemplated under the provisions of Section 4205 of the Government Code, and of Chapter 1 of Title 4 of Part 3 of the Code of Civil Procedure, of the State of California.

This bond is executed and filed in connection with said contract or agreement hereunto attached to comply with each and all of the provisions of the laws of the State of California above mentioned or referred to, and of all amendments thereto, and the obligors so intend and do hereby bind themselves accordingly.

**LABOR AND MATERIAL BOND B2020-13 (CONTINUED)**

The said Surety, for value received, hereby stipulates and agrees that no amendment, change, extension of time, alteration, or addition to said contract or agreement, or of any feature or item or items of performance required therein or thereunder, shall in any manner affect its obligations on or under this bond; and said Surety does hereby waive notice of any such amendment, change, extension of time, alteration, or addition to said contract or agreement, and of any feature or item or items of performance required therein or thereunder.

**EXECUTED, SEALED AND DATED** this \_\_\_\_\_ day of \_\_\_\_\_, 20 \_\_\_\_\_

CORPORATE SEAL

PRINCIPAL:

BY \_\_\_\_\_

CORPORATE SEAL

SURETY:

BY \_\_\_\_\_

Name: \_\_\_\_\_

Local Address: \_\_\_\_\_

\_\_\_\_\_

Phone No.: \_\_\_\_\_

Fax No.: \_\_\_\_\_

## **CONTRACT SERVICES AGREEMENT**

This CONTRACT SERVICES AGREEMENT (“Agreement”) is made and entered into as of Date (the “Effective Date”), by and between the CITY OF TORRANCE, a municipal corporation (“CITY”), and Contractor Name, type of entity (“CONTRACTOR”).

### **RECITALS:**

- A. The CITY wishes to retain the services of an experienced and qualified CONTRACTOR to Description of Project Project Name & Bid Number;
- B. In order to obtain the desired services, The CITY has circulated a Notice Inviting Bids for the Description of Notice Inviting Bid Project Name & Bid Number (the “NIB”); and
- C. CONTRACTOR has submitted a Bid (the “Bid”) in response to the NIB. CONTRACTOR represents that it is qualified to perform those services requested in the Plans and Specifications. Based upon its review of all Bids submitted in response to the NIB, The CITY is willing to award the contract to CONTRACTOR.

### **AGREEMENT:**

#### **1. SERVICES TO BE PERFORMED BY CONTRACTOR**

CONTRACTOR will provide the services and install those materials listed in the Plans and Specifications, which are on file in the General Services Department. The NIB and the Plans and Specifications are made a part of this Agreement. A copy of the Bid is attached as Exhibit A.

#### **2. TERM**

Unless earlier terminated in accordance with Paragraph 4 below, this Agreement will continue in full force and effect for One/Two Year(s) from the Effective Date.

#### **3. COMPENSATION**

- A. CONTRACTOR’s Fee.

For services rendered pursuant to this Agreement, CONTRACTOR will be paid in accordance with CONTRACTOR’s Bid; provided, however, that in no event will the total amount of money paid the CONTRACTOR, for services initially contemplated by this Agreement, exceed the sum of \$Insert Dollar Amount (“Agreement Sum”), plus a contingency of \$Insert Dollar Amount, if first approved in writing by the CITY.

- B. Schedule of Payment.  
Provided that the CONTRACTOR is not in default under the terms of this Agreement, upon presentation of an invoice, CONTRACTOR will be paid monthly, within 30 days after the date of the monthly invoice.

**4. TERMINATION OF AGREEMENT**

A. Termination by CITY for Convenience.

1. CITY may, at any time, terminate the Agreement for CITY's convenience and without cause.
2. Upon receipt of written notice from CITY of such termination for CITY's convenience, CONTRACTOR will:
  - a) cease operations as directed by CITY in the notice;
  - b) take actions necessary, or that CITY may direct, for the protection preservation of the work; and
  - c) except for work directed to be performed prior to the effective date of termination stated in the notice, terminate all existing subcontracts and purchase orders and enter into no further subcontracts and purchase orders.
3. In case of such termination for CITY's convenience, CONTRACTOR will be entitled to receive payment for work executed; and costs incurred by reason of such termination, along with reasonable overhead and profit on the work not executed.

B. Termination for Cause.

1. If either party fails to perform any term, covenant or condition in this Agreement and that failure continues for 15 calendar days after the nondefaulting party gives the defaulting party notice of the failure to perform, this Agreement may be terminated for cause; provided, however, that if during the notice period the defaulting party has promptly commenced and continues diligent efforts to remedy the default, the defaulting party will have such additional time as is reasonably necessary to remedy the default.
2. In the event this Agreement is terminated for cause by the default of the CONTRACTOR, the CITY may, at the expense of the CONTRACTOR and its surety, complete this Agreement or cause it to be completed. Any check or bond delivered to the CITY in connection with this Agreement, and the money payable thereon, will be forfeited to and remain the property of the CITY. All moneys due the CONTRACTOR under the terms of this Agreement will be retained by the CITY, but the retention will not release the CONTRACTOR and its surety from liability for the default. Under these circumstances, however, the CONTRACTOR and its surety will be credited with the amount of money retained, toward any amount by which the cost of completion exceeds the Agreement Sum and any amount authorized for extra services.
3. Termination for cause will not affect or terminate any of the rights of the CITY as against the CONTRACTOR or its surety then existing, or which may thereafter accrue because of the default; this provision is in addition to all other rights and remedies available to the CITY under law.

C. Termination for Breach of Law.

In the event the CONTRACTOR or any of its officers, directors, shareholders, employees, agents, subsidiaries or affiliates is convicted (i) of a criminal offense as an incident to

obtaining or attempting to obtain a public or private contract or subcontract, or in the performance of a contract or subcontract; (ii) under state or federal statutes of embezzlement, theft, forgery, bribery, falsification or destruction of records, receiving stolen property, or any other offense indicating a lack of business integrity or business honesty which currently, seriously, and directly affects responsibility as a public consultant or contractor; (iii) under state or federal antitrust statutes arising out of the submission of bids or proposals; or (iv) of violation of Paragraph 19 of this Agreement; or for any other cause the CITY determines to be so serious and compelling as to affect CONTRACTOR's responsibility as a public consultant or contractor, including but not limited to, debarment by another governmental agency, then the CITY reserves the unilateral right to terminate this Agreement or to impose such other sanctions (which may include financial sanctions, temporary suspensions or any other condition deemed appropriate short of termination) as it deems proper. The CITY will not take action until CONTRACTOR has been given notice and an opportunity to present evidence in mitigation.

**5. FORCE MAJEURE**

If any party fails to perform its obligations because of strikes, lockouts, labor disputes, embargoes, acts of God, inability to obtain labor or materials or reasonable substitutes for labor or materials, governmental restrictions, governmental regulations, governmental controls, judicial orders, enemy or hostile governmental action, civil commotion, fire or other casualty, or other causes beyond the reasonable control of the party obligated to perform, then that party's performance shall be excused for a period equal to the period of such cause for failure to perform.

**6. RETENTION OF FUNDS**

CONTRACTOR authorizes the CITY to deduct from any amount payable to CONTRACTOR (whether or not arising out of this Agreement) any amounts the payment of which may be in dispute or that are necessary to compensate the CITY for any losses, costs, liabilities, or damages suffered by the CITY, and all amounts for which the CITY may be liable to third parties, by reason of CONTRACTOR's negligent acts or omissions or willful misconduct in performing or failing to perform CONTRACTOR's obligations under this Agreement. In the event that any claim is made by a third party, the amount or validity of which is disputed by CONTRACTOR, or any indebtedness exists that appears to be the basis for a claim of lien, the CITY may withhold from any payment due, without liability for interest because of the withholding, an amount sufficient to cover the claim. The failure of the CITY to exercise the right to deduct or to withhold will not, however, affect the obligations of CONTRACTOR to insure, indemnify, and protect the CITY as elsewhere provided in this Agreement.

**7. THE CITY'S REPRESENTATIVE**

City Representative is designated as the "City Representative," authorized to act in its behalf with respect to the work and services specified in this Agreement and to make all decisions in connection with this Agreement. Whenever approval, directions, or other actions are required by the CITY under this Agreement, those actions will be taken by the City Representative, unless otherwise stated. The City Manager has the right to designate another City Representative at any time, by providing notice to CONTRACTOR.

**8. CONTRACTOR REPRESENTATIVE(S)**

The following principal(s) of CONTRACTOR are designated as being the principal(s) and representative(s) of CONTRACTOR authorized to act in its behalf with respect to the work specified in this Agreement and make all decisions in connection with this Agreement:

Representative 1  
Representative 2

**9. INDEPENDENT CONTRACTOR**

The CONTRACTOR is, and at all times will remain as to the CITY, a wholly independent contractor. Neither the CITY nor any of its agents will have control over the conduct of the CONTRACTOR or any of the CONTRACTOR's employees, except as otherwise set forth in this Agreement. The CONTRACTOR may not, at any time or in any manner, represent that it or any of its agents or employees are in any manner agents or employees of the CITY. CITY has no duty, obligation, or responsibility to CONTRACTOR's agents or employees under the Affordable Care Act. CONTRACTOR is solely responsible for any tax penalties associated with the failure to offer affordable coverage to its agents and employees under the Affordable Care Act and any other liabilities, claims and obligations regarding compliance with the Affordable Care Act with respect to CONTRACTOR's agents and employees. CITY is not responsible and shall not be held liable for CONTRACTOR's failure to comply with CONTRACTOR's duties, obligations, and responsibilities under the Affordable Care Act. CONTRACTOR agrees to defend, indemnify and hold CITY harmless for any and all taxes and penalties that may be assessed against CITY as a result of CONTRACTOR's obligations under the Affordable Care Act relating to CONTRACTOR's agents and employees.

**10. BUSINESS LICENSE**

The CONTRACTOR must obtain a City business license prior to the start of work under this Agreement, unless CONTRACTOR is qualified for an exemption.

**11. OTHER LICENSES AND PERMITS**

CONTRACTOR warrants that it has all professional, contracting and other permits and licenses required to undertake the work contemplated by this Agreement.

**12. FAMILIARITY WITH WORK**

By executing this Agreement, CONTRACTOR warrants that CONTRACTOR (a) has thoroughly investigated and considered the scope of services to be performed, (b) has carefully considered how the services should be performed, and (c) fully understands the facilities, difficulties and restrictions attending performance of the services under this Agreement. If the services involve work upon any site, CONTRACTOR warrants that CONTRACTOR has or will investigate the site and is or will be fully acquainted with the conditions there existing, prior to commencement of services set forth in this Agreement. Should CONTRACTOR discover any latent or unknown conditions that will materially affect the performance of the services set forth in this Agreement, CONTRACTOR must immediately inform the CITY of that fact and may not proceed except at CONTRACTOR's risk until written instructions are received from the CITY.

**13. CARE OF WORK**

CONTRACTOR must adopt reasonable methods during the life of the Agreement to furnish continuous protection to the work, and the equipment, materials, papers, documents, plans, studies and other components to prevent losses or damages, and will be responsible for all damages, to persons or property, until acceptance of the work by the CITY, except those losses or damages as may be caused by the CITY's own negligence.

**14. CONTRACTOR'S ACCOUNTING RECORDS; OTHER PROJECT RECORDS**

Records of the CONTRACTOR's time pertaining to the project, and records of accounts between the CITY and the CONTRACTOR, will be kept on a generally recognized accounting basis. CONTRACTOR will also maintain all other records, including without limitation specifications, drawings, progress reports and the like, relating to the project. All records will be available to the CITY during normal working hours. CONTRACTOR will maintain these records for three years after final payment.

**15. PREVAILING WAGE**

All Services rendered pursuant to this agreement must be provided in accordance with all ordinances, resolutions, statutes, rules, regulations, and laws of City and any Federal, State, or local governmental agency of competent jurisdiction. Contractor is aware of the requirements of California Labor Code Sections 1720, et seq., and 1770, et seq., as well as of California Code of Regulations, Title 8, Sections 1600, et seq., (collectively, the "Prevailing Wage Laws"), which require the payment of prevailing wage rates and the performance of other requirements on "Public works" and "Maintenance" projects. If the Services are being performed as part of an applicable "Public works" or "Maintenance" project, as defined by the Prevailing Wage Laws, and if the total compensation is ONE THOUSAND DOLLARS (\$1,000) or more, Contractor agrees to fully comply with the Prevailing Wage Laws including, but not limited to, requirements related to the maintenance of payroll records and the employment of apprentices.

Pursuant to California Labor Code Section 1725.5, no contractor or subcontractor may be awarded a contract for public work on a "Public works" project unless registered with the California Department of Industrial Relations ("DIR") at the time the contract is awarded. If the Services are being performed as part of an applicable "Public works" or "Maintenance" project, as defined by the Prevailing Wage Laws, this project is subject to compliance monitoring and enforcement by the California Department of Industrial Relations ("DIR"). Contractor will maintain and will require all subcontractors to maintain valid and current DIR Public Works Contractor registration during the term of this Agreement. Contractor must notify City in writing immediately, and in no case more than twenty-four (24) hours, after receiving any information that Contractor's or any of its subcontractor's DIR registration status has been suspended, revoked, expired, or otherwise changed.

It is understood that it is the responsibility of Contractor to determine the correct salary scale. Contractor will make copies of the prevailing rates of per diem wages for each craft, classification, or type of worker needed to execute the Services available to interested parties upon request, and post copies at Contractor's principal place of business and at the project site, if any. The statutory penalties for failure to pay prevailing wage or to comply with State wage and hour laws will be enforced. Contractor must forfeit to City TWENTY FIVE DOLLARS (\$25.00) per day for each worker who works in excess of the minimum working hours when Contractor



does not pay overtime. In accordance with the provisions of Labor Code Sections 1810 et seq., eight (8) hours is the legal working day.

Contractor must also comply with State law requirements to maintain payroll records and must provide for certified records and inspection of records as required by California Labor Code Section 1770 et seq., including Section 1776. Contractor will defend (with counsel selected by City), indemnify, and hold City, its elected officials, officers, employees, and agents free and harmless from any claim or liability arising out of any failure or alleged failure to comply with the Prevailing Wage Laws. It is agreed by the parties that, in connection with performance of the Services, including, without limitation, any and all "Public works" (as defined by the Prevailing Wage Laws), Contractor will bear all risks of payment or non-payment of prevailing wages under California law and/or the implementation of Labor Code Section 1781, as the same may be amended from time to time, and/or any other similar law. Contractor acknowledges and agrees that it will be independently responsible for reviewing the applicable laws and regulations and effectuating compliance with those laws. Contractor will require the same of all subcontractors.

**16. INDEMNIFICATION**

CONTRACTOR will indemnify, defend, and hold harmless CITY, the City Council, each member thereof, present and future, its officers, agents and employees from and against any and all liability, expenses, including defense costs and legal fees, and claims for damages whatsoever, including, but not limited to, those arising from breach of contract, bodily injury, death, personal injury, property damage, loss of use, or property loss however the same may be caused and regardless of the responsibility for negligence. The obligation to indemnify, defend and hold harmless includes, but is not limited to, any liability or expense, including defense costs and legal fees, arising from the negligent acts or omissions, or willful misconduct of CONTRACTOR, its officers, employees, agents, subcontractors or vendors. It is further agreed, CONTRACTOR's obligations to indemnify, defend and hold harmless will apply even in the event of concurrent negligence on the part of CITY, the City Council, each member thereof, present and future, or its officers, agents and employees, except for liability resulting solely from the negligence or willful misconduct of CITY, its officers, employees or agents. Payment by CITY is not a condition precedent to enforcement of this indemnity. In the event of any dispute between CONTRACTOR and CITY, as to whether liability arises from the sole negligence of the CITY or its officers, employees, agents, subcontractors or vendors, CONTRACTOR will be obligated to pay for CITY's defense until such time as a final judgment has been entered adjudicating the CITY as solely negligent. CONTRACTOR will not be entitled in the event of such a determination to any reimbursement of defense costs including but not limited to attorney's fees, expert fees and costs of litigation.

**17. NON-LIABILITY OF THE CITY'S OFFICERS AND EMPLOYEES**

No officer or employee of the CITY will be personally liable to CONTRACTOR, in the event of any default or breach by the CITY or for any amount that may become due to CONTRACTOR.

**18. INSURANCE**

- A. CONTRACTOR and its subcontractors must maintain for the duration of the Agreement at its sole expense the following insurance, which will be full coverage not subject to self-insurance provisions:
- (1) Automobile Liability, including owned, non-owned and hired vehicles, with at least the following limits of liability:
    - (a) Primarily Bodily Injury with limits of at least \$500,000 per person, \$1,000,000 per occurrence; and
    - (b) Primary Property Damage of at least \$250,000 per occurrence; or
    - (c) Combined single limits of \$1,000,000 per occurrence.
  - (2) Commercial General Liability including coverage for premises, products and completed operations, independent contractors, personal injury and contractual obligations with combined single limits of coverage of at least \$2,000,000 per occurrence, \$4,000,000 aggregate.
  - (3) Workers' compensation coverage as required by the Labor Code of the State of California and, if workers' compensation is required, employer's liability insurance with minimum limits of (\$1,000,000) per occurrence or occupational illness. The Workers' Compensation policy shall be endorsed with a waiver of subrogation in favor of the CITY for all work performed by the CONTRACTOR, its employees, agents and subcontractors.
- B. The insurance provided by CONTRACTOR will be primary and non-contributory.
- C. CITY, the Successor Agency to the Former Redevelopment Agency of the City of Torrance, the City Council and each member thereof, members of boards and commissions, very officer, agent, official, employee and volunteer must be named as additional insureds under the automobile and general liability policies. Additional insured coverage endorsement must also apply to all work performed by CONTRACTOR.
- D. CONTRACTOR must provide certificates of insurance including all required amendatory endorsements (or copies of the applicable policy language effecting coverage required by this clause) indicating appropriate coverage, to the City Clerk of the City of Torrance before the commencement of work.
- E. Each insurance policy required by this Paragraph must contain a provision that no termination, cancellation or change of coverage can be made without notice to the CITY.
- F. CONTRACTOR must include all subcontractors as insureds under its policies or must furnish separate certificates and endorsements for each subcontractor. All coverage for subcontractors will be subject to all of the requirements of this Paragraph 18.

- G. If the CONTRACTOR maintains broader coverage and/or higher limits than the minimums shown above, the CITY requires and shall be entitled to the broader coverage and/or the higher limits maintained by the CONTRACTOR. Any available insurance proceeds in excess of the specified minimum limits of insurance and coverage shall be available to the CITY.
- H. The procuring of insurance shall not be construed as a limitation on liability nor as full performance of the indemnification provisions of the CONTRACTOR.
- I. CONTRACTOR hereby grants to CITY a waiver of any right to subrogation which any insurer of said CONTRACTOR may acquire against the CITY by virtue of the payment of any loss under such insurance. CONTRACTOR agrees to obtain any endorsement that may be necessary to affect this waiver of subrogation, but this provision applies regardless of whether or not the CITY has received a waiver of subrogation endorsement from the insurer.

**19. SUFFICIENCY OF INSURERS**

Insurance required by this Agreement will be satisfactory only if issued by companies admitted to do business in California, rated “A” or better in the most recent edition of Best’s Key Rating Guide, and only if they are of a financial category Class VII or better, unless these requirements are waived by the Risk Manager of the CITY (“Risk Manager”) due to unique circumstances. In the event the Risk Manager determines that the work or services to be performed under this Agreement creates an increased or decreased risk of loss to the CITY, the CONTRACTOR agrees that the minimum limits of any insurance policies and/or the performance bond required by this Agreement may be changed accordingly upon receipt of written notice from the Risk Manager; provided that CONTRACTOR will have the right to appeal a determination of increased coverage by the Risk Manager to the City Council of the CITY within 10 days of receipt of notice from the Risk Manager.

**20. CONFLICT OF INTEREST**

- A. No officer or employee of the CITY may have any financial interest, direct or indirect, in this Agreement, nor may any officer or employee participate in any decision relating to the Agreement that effects the officer or employee’s financial interest or the financial interest of any corporation, partnership or association in which the officer or employee is, directly or indirectly interested, in violation of any law, rule or regulation.
- B. No person may offer, give, or agree to give any officer or employee or former officer or employee, nor may any officer or employee solicit, demand, accept, or agree to accept from another person, a gratuity or an offer of employment in connection with any decision, approval, disapproval, recommendation, preparation or any part of a program requirement or a purchase request, influencing the content of any specification or procurement standard, rendering of advice, investigation, auditing, or in any other advisory capacity in any way pertaining to any program requirement, contract or subcontract, or to any solicitation or proposal.

**21. NOTICE**

- A. All notices, requests, demands, or other communications under this Agreement will be in writing. Notice will be sufficiently given for all purposes as follows:
1. Personal delivery. When personally delivered to the recipient: notice is effective on delivery.
  2. First Class mail. When mailed first class to the last address of the recipient known to the party giving notice: notice is effective three mail delivery days after deposit in an United States Postal Service office or mailbox.
  3. Certified mail. When mailed certified mail, return receipt requested: notice is effective on receipt, if delivery is confirmed by a return receipt.
  4. Overnight delivery. When delivered by an overnight delivery service, charges prepaid or charged to the sender's account: notice is effective on delivery, if delivery is confirmed by the delivery service.
  5. Facsimile transmission. When sent by fax to the last fax number of the recipient known to the party giving notice: notice is effective on receipt. Any notice given by fax will be deemed received on the next business day if it is received after 5:00 p.m. (recipient's time) or on a non-business day.
  7. Addresses for purpose of giving notice are as follows:

CONTRACTOR: Contractor's Name and Address

Fax: Insert Fax Number

CITY: City Clerk  
City of Torrance  
3031 Torrance Boulevard  
Torrance, CA 90503  
Fax: (310) 618-2931

with a copy to: Attn: Project Manager's Name  
Department Name  
Address  
Torrance, CA 90503  
Fax: Insert Fax Number

- B. Any correctly addressed notice that is refused, unclaimed, or undeliverable because of an act or omission of the party to be notified, will be deemed effective as of the first date the notice was refused, unclaimed or deemed undeliverable by the postal authorities, messenger or overnight delivery service.
- C. Either party may change its address or fax number by giving the other party notice of the change in any manner permitted by this Agreement.

**22. PROHIBITION AGAINST ASSIGNMENT AND SUBCONTRACTING**

This Agreement and all exhibits are binding on the heirs, successors, and assigns of the parties. The Agreement may not be assigned or subcontracted by either the CITY or CONTRACTOR without the prior written consent of the other.

**23. INTEGRATION; AMENDMENT**

This Agreement represents the entire understanding of the CITY and CONTRACTOR as to those matters contained in it. No prior oral or written understanding will be of any force or effect with respect to the terms of this Agreement. The Agreement may not be modified or altered except in writing signed by both parties.

**24. INTERPRETATION**

The terms of this Agreement should be construed in accordance with the meaning of the language used and should not be construed for or against either party by reason of the authorship of this Agreement or any other rule of construction that might otherwise apply. To the extent that the terms of the Bid or Proposal are inconsistent with the terms of this Agreement, the terms of this Agreement shall control.

**25. SEVERABILITY**

If any part of this Agreement is found to be in conflict with applicable laws, that part will be inoperative, null and void insofar as it is in conflict with any applicable laws, but the remainder of the Agreement will remain in full force and effect.

**26. TIME OF ESSENCE**

Time is of the essence in the performance of this Agreement.

**27. GOVERNING LAW; JURISDICTION**

This Agreement will be administered and interpreted under the laws of the State of California. Jurisdiction of any litigation arising from the Agreement will be in Los Angeles County, California.

**28. COMPLIANCE WITH STATUTES AND REGULATIONS**

CONTRACTOR will be knowledgeable of and will comply with all applicable federal, state, county and city statutes, rules, regulations, ordinances and orders.

**29. WAIVER OF BREACH**

No delay or omission in the exercise of any right or remedy by a nondefaulting party on any default will impair the right or remedy or be construed as a waiver. A party's consent or approval of any act by the other party requiring the party's consent or approval will not be deemed to waive or render unnecessary the other party's consent to or approval of any subsequent act. Any waiver by either party of any default must be in writing and will not be a waiver of any other default concerning the same or any other provision of this Agreement.

**30. ATTORNEY'S FEES**

Except as provided for in Paragraph 16, in any dispute, litigation, arbitration, or other proceeding by which one party either seeks to enforce its rights under this Agreement (whether in contract, tort or both) or seeks a declaration of any rights or obligations under this Agreement, the prevailing party will be awarded reasonable attorney's fees, together with any costs and expenses, to resolve the dispute and to enforce any judgment.

**31. EXHIBITS**

All exhibits identified in this Agreement are incorporated into the Agreement by this reference.

**32. CONTRACTOR'S AUTHORITY TO EXECUTE**

The persons executing this Agreement on behalf of the CONTRACTOR warrant that (i) the CONTRACTOR is duly organized and existing; (ii) they are duly authorized to execute this Agreement on behalf of the CONTRACTOR; (iii) by so executing this Agreement, the CONTRACTOR is formally bound to the provisions of this Agreement; and (iv) the entering into this Agreement does not violate any provision of any other Agreement to which the CONTRACTOR is bound.

**33. PUBLIC RECORDS ACT**

Any documents submitted by the CONTRACTOR; all information obtained in connection with the CITY's right to audit and inspect the CONTRACTOR's documents, books, and accounting records pursuant to paragraph 14 Contractor's Accounting Records; Other Project Records; as well as those documents which were required to be submitted in response to the Bid used in the solicitation process for this Contract, become the exclusive property of the City. All such documents become a matter of public record and shall be regarded as public records. Exceptions will be those elements in the California Government Code Section 6250 et seq. (Public Records Act) and which are marked "trade secret", "confidential", or "proprietary". The CITY shall not in any way be liable or responsible for the disclosure of any such records including, without limitation, those so marked, if disclosure is required by law, or by an order issued by a court of competent jurisdiction.

///

///

///

///

In the event the CITY is required to defend an action on a Public Records Act request for any of the aforementioned documents, information, books, records, and/or contents of a proposal marked "trade secret", "confidential", or "proprietary", the CONTRACTOR agrees to defend and indemnify the CITY from all costs and expenses, including reasonable attorney's fees, in action or liability arising under the Public Records Act.

CITY OF TORRANCE,  
a municipal corporation

Firm Name  
Type of Entity

\_\_\_\_\_  
Patrick J. Furey, Mayor

By: \_\_\_\_\_  
Signer Name, Title

ATTEST:

\_\_\_\_\_  
Rebecca Poirier, MMC  
City Clerk

APPROVED AS TO FORM:

PATRICK Q. SULLIVAN  
City Attorney

By: \_\_\_\_\_

Attachment:      Exhibit A: Bid  
Rev. 0819

**EXHIBIT A**

**Bid**



**PART F**  
**SPECIFICATIONS**

## 1.1 INSTALLATION REQUIREMENTS

- A. The contractor must purchase and install the equipment specified on the Bid Proposal Form in **Section D**. The contractor must follow the installation procedures outlined by the fixture manufacturer. The contractor will ensure the installation meets these installation procedures so as to resolve any potential glare, wiring or other issues that reduce performance or void warranty of the product. All existing fixtures and associated components must be properly disposed to meet all federal, state and local requirements.
- B. LED Fixture Compliance:
1. LED fixtures MUST be qualified by The DesignLights Consortium®, and be listed at <http://www.designlights.org/>. Excluding pool light fixtures.
  2. Replacement fixtures shall be compatible in size and shape as existing and shall fit into existing space and connect to existing lighting circuiting. Field verify prior to purchase.
  3. Voltage: 120, 277 or 480-V ac. Field verify prior to purchase or provide multitap ballast.
  4. Mounting: Match existing fixture mounting.
  5. Nominal Dimensions: Match existing.
  6. Ballast Types and Features: Electronic and Electronic Dimming as required, field verify.
  7. External Finish: Match existing.
  8. Trim and Hardware: Match existing.
  9. Special Environmental Conditions: Damp or wet location listed as required to match existing.
- C. Quality Assurance
1. Installer should be a licensed electrical contractor and have experience with installing LED lighting fixtures and provide a minimum 1-year warranty for the system against any defects in materials or workmanship.
  2. Prior to purchase of proposed fixtures, the installer will verify that fixture light output is sufficient for each area being upgraded.
  3. Electrical Components, Devices, and Accessories: Listed and labeled as defined in NFPA 70, Article 100, by a testing agency acceptable to authorities having jurisdiction, and marked for intended use.
  4. Comply with NFPA 70.

## 1.2 COORDINATION

- A. Coordinate layout and installation of lighting fixtures and suspension system with other construction that penetrates ceilings or is supported by them, including HVAC equipment, fire-suppression system, and partition assemblies.

## 1.3 EQUIPMENT WARRANTY

- A. All electrical parts and equipment shall be fully guaranteed against defects in parts, for a minimum of five years. Contractor shall list and supply manufacturer's standard guarantees for the LED's and all other electrical equipment, fixtures, parts, and controls. (Please attach copies of manufacturer's standard guarantees). These warranties shall be in addition to, and not a limitation of, other rights the Owner may have under General Condition's provisions of the Contract Documents.

#### 1.4 FIXTURES AND COMPONENTS, GENERAL

- A. Recessed Fixtures: Comply with NEMA LE 4 for ceiling compatibility for recessed fixtures.
- B. HID Fixtures: Comply with UL 1598. Where LER is specified, test according to NEMA LE 5B.
- C. Metal Parts: Free of burrs and sharp corners and edges.
- D. Sheet Metal Components: Steel, unless otherwise indicated. Form and support to prevent warping and sagging.
- E. Doors, Frames, and Other Internal Access: Smooth operating, free of light leakage under operating conditions, and designed to permit relamping without use of tools. Designed to prevent doors, frames, lenses, diffusers, and other components from falling accidentally during relamping and when secured in operating position.

#### 1.5 HIGH-INTENSITY-DISCHARGE BALLASTS

- A. Comply with NEMA C82.4 and UL 1029. Shall include the following features, unless otherwise indicated.
  - 1. Premium-grade HPF regulating autotransformers.
  - 2. Ballast is capable of providing consistent lamp starting down to -20 °F.

#### 1.6 HIGH-INTENSITY-DISCHARGE LAMPS

- A. Pulse Start Metal Halide Lamps: ANSI C78.1372, wattage and burning position as scheduled, CRI 68 (minimum), and color temperature 4000K and minimum life of 26,000 hours for 875 watt lamp.

#### 1.7 FIXTURE SUPPORT COMPONENTS

- A. Single-Stem Hangers: ½-inch (13mm) steel tubing with swivel ball fittings and ceiling canopy. Finish same as fixture.
- B. Twin-Stem Hangers: Two, ½-inch (13mm) steel tubes with single canopy designed to mount a single fixture. Finish same as fixture.
- C. Wires: ASTM A 641/A 641M, Class 3, soft temper, zinc-coated, 12 gage (2.68 mm).
- D. Wires for Humid Spaces: ASTM A580/A 580M, Composition 302 or 304 annealed stainless steel, 12 gage (2.68 mm).
- E. Rod Hangers: 3/16-inch- (5-mm-) minimum diameter, cadmium-plated, threaded steel rod.
- F. Hook Hangers: Integrated assembly matched to fixture and line voltage and equipped with threaded attachment, cord, and locking-type plug.
- G. Aircraft Cable Support: Use cable, anchorages, and intermediate supports recommended by fixture manufacturer.

## 1.8 CONNECTIONS

Tighten electrical connectors and terminals according to manufacturer's published torque-tightening values. If manufacturer's torque values are not indicated, use those specified in UL 486A and UL 486B.

## 1.9 FIELD QUALITY CONTROL

- A. Inspect each installed fixture for damage. Replace damaged fixtures and components.
- B. Verify normal operation of each fixture after installation.
- C. Test for Emergency Lighting: Interrupt power supply to demonstrate proper operation. Verify transfer from normal power to battery and retransfer to normal.
- D. Prepare a written report of tests, inspections, observations, and verifications indicating and interpreting results. If adjustments are made to lighting system, retest to demonstrate compliance with standards.
- E. Corroded Fixtures: During warranty period, replace fixtures that show any signs of corrosion.

## 1.10 TRAINING

- A. Contractor shall schedule and conduct maintenance training with Owner's maintenance personnel. Training sessions should include a demonstration of all maintenance and repair procedures that end user personnel would normally perform.

**Note: Equipment must be an ENERGY STAR-approved model<sup>3</sup> when final inspection is completed to be eligible for an SCE energy efficiency incentive. It is the applicant or applicant's trade professional's responsibility to ensure the installed equipment is an ENERGY STAR-approved model when installed.**

**To confirm the product is approved by SCE refer to the website:**

**<https://www.designlights.org/search/>**

## ITEMIZED LIGHTING SURVEY AND SPECIFICATIONS

Park Name	Area	Existing Fixture Type	SCE Solution Code	Replacement Description	Qty.	Existing Lamp Type	Proposed Operating Hours	Proposed Manuf.	Proposed M/N
Delthorne	Electric Room	Wallpack	LT-96754	Exterior HPS to LED	1	HPS 70	4100	ATG Electronics	WPDS-28-40-G3
Delthorne	Restroom	Surface mount	LT-96754	Exterior MH to LED	4	MH 175	4100	RAB	VANLED40
Delthorne	Basketball court	Flood Double fixture	LT-85834	Exterior MH to LED	4	MH 400	1250	ATG Electronics	AS15-40-T3-7PIN MSF-AS-00
Delthorne	Parking lot	Flood Double fixture	LT-19132	Exterior MH to LED	2	MH 250	3485	MESTER	27V40KDT3/ SPAL04DA /JL-241C-Kit
Delthorne	Park area	Flood Double fixture	LT-19132	Exterior MH to LED	2	MH 250	3485	MESTER	27V40KDT3/ SPAL04DA /JL-241C-Kit
Delthorne	Park area	Flood Triple fixture	LT-19132	Exterior MH to LED	3	MH 250	3485	MESTER	27V40KDT3/ SPAL04DA /JL-241C-Kit
Delthorne	Pathway	Flood	LT-19132	Exterior MH to LED	1	MH 250	3485	MESTER	27V40KDT3/ SPAL04DA /JL-241C-Kit
Delthorne	Pathway	Shoebox	LT-19132	Exterior MH to LED	14	MH 250	3485	MESTER	27V40KDT3/ SQAL04DA /JL-241C-Kit
Discovery	Table area	Surface mount	LT-96754	Exterior MH to LED	1	MH 175	1400	RAB	VANLED40
Discovery	Pathway	Post-top	LT-19132	Exterior MH to LED	6	MH 175	1400	RAB	LED5T78N/480
El Nido	Park area	Area lighter	LT-19132	Exterior MH to LED	4	MH 250	4100	MESTER	27V40KDT3/ SPAL04DA /JL-241C-Kit
El Nido	Rec building	Surface mount	LT-96754	Exterior MH to LED	0	MH 150	4100	RAB	VANLED40
El Nido	Parking lot	Area lighter	LT-19132	Exterior MH to LED	4	MH 250	4100	MESTER	27V40KDT3/ SPAL04DA /JL-241C-Kit
El Nido	Parking lot	Area lighter	LT-19132	Exterior MH to LED	2	MH 250	4100	MESTER	27V40KDT3/ SPAL04DA /JL-241C-Kit
El Retiro	Table area	Wallpacks	LT-96754	Exterior MH to LED	6	MH 175	4100	ATG Electronics	WPDS-60-40-G3
El Retiro	Building exterior	Surface mount	LT-96754	Exterior MH to LED	1	MH 175	4100	RAB	VANLED40
El Retiro	Building exterior	Wallpacks	LT-96754	Exterior MH to LED	14	MH 175	4100	ATG Electronics	WPDS-60-40-G3
El Retiro	Tennis court	Flood	LT-85834	Exterior MH to LED	12	MH 400	1250	ATG Electronics	AS15-40-V-T3-7PIN MSF-AS-00
El Retiro	Pathway	Pumpkin head	LT-19132	Exterior MH to LED	1	HPS 200	3485	RAB	LED5T78N/480
El Retiro	Parking lot	Flood	LT-19132	Exterior MH to LED	8	MH 400	3485	ATG Electronics	AS15-40-V-T3-7PIN MSF-AS-00
Hickory	Restroom	Surface mount	LT-96754	Exterior MH to LED	2	MH 175	4100	RAB	VANLED40
Hickory	Tennis court	Shoebox	LT-85834	Exterior MH to LED	6	MH 1000	1800	ATG Electronics	AS30-40-V-T3-7PIN MAM-AS-0S
La Carretara	Basketball court	Flood	LT-85834	Exterior MH to LED	4	MH 400	3485	ATG Electronics	AS15-40-V-T3-7PIN MSF-AS-00
La Carretara	Park area	Flood	LT-19132	Exterior MH to LED	2	MH 250	3485	MESTER	27V40KDT3/ SPAL04DA /JL-241C-Kit
La Carretara	Park area	Shoebox	LT-19132	Exterior MH to LED	3	MH 250	3485	MESTER	27V40KDT3/ SQAL04DA /JL-241C-Kit
La Romeria	Tennis court	Flood	LT-85834	Exterior MH to LED	6	MH 1000	800	MESTER	27V40KDT3/ SPAL04DA /JL-241C-Kit
La Romeria	Basketball court	Flood	LT-85834	Exterior MH to LED	2	MH 175	800	MESTER	27V40KDT3/ SPAL04DA /JL-241C-Kit
La Romeria	Basketball court	Flood	LT-85834	Exterior MH to LED	6	MH 1000	800	MESTER	27V40KDT3/ SPAL04DA /JL-241C-Kit
La Romeria	Rec building	Flood	LT-96754	Exterior MH to LED	1	MH 175	4000	MESTER	27V40KDT3/ SPAL04DA /JL-241C-Kit
La Romeria	Rec building	Surface mount	LT-96754	Exterior MH to LED	3	MH 175	4000	RAB	VANLED40

## ITEMIZED LIGHTING SURVEY AND SPECIFICATIONS

Park Name	Area	Existing Fixture Type	SCE Solution Code	Replacement Description	Qty.	Existing Lamp Type	Proposed Operating Hours	Proposed Manuf.	Proposed M/N
Lago Seco	Restroom	wallpack	LT-96754	Exterior HPS to LED	2	MH 250	3800	ATG Electronics	WPDS-60-40-G3
Lago Seco	Restroom	wallpack	LT-96754	Exterior MH to LED	1	MH 175	3800	ATG Electronics	WPDS-60-40-G3
Osage	parking lot	flood	LT-19132	Exterior MH to LED	2	MH 250	1600	MESTER	27V40KDT3/ SPAL04DA /JL-241C-Kit
Paradise	Rec building	Surface mount	LT-96754	Exterior MH to LED	3	MH 175	4000	RAB	VANLED40
Paradise	Tennis courts	Shoebox	LT-85834	Exterior MH to LED	16	MH 1000	1150	ATG Electronics	AS30-40-V-T3-7PIN MAM-AS-05
Pequeno	Park area	Pumpkin head	LT-19132	Exterior MH to LED	1	MH 150	3485	RAB	LED5T78N/480
Pequeno	Park area	Area lighter	LT-19132	Exterior MH to LED	1	HPS 200	3485	MESTER	27V40KDT3/ SPAL04DA /JL-241C-Kit
Pueblo	Table area	Surface mount	LT-96754	Exterior MH to LED	8	MH 50	1250	RAB	VANLED40
Pueblo	Basketball court	Flood	LT-19132	Exterior MH to LED	1	MH 175	1250	MESTER	27V40KDT3/ SPAL04DA /JL-241C-Kit
Pueblo	Basketball court	Flood	LT-19132	Exterior MH to LED	2	MH 400	1250	ATG Electronics	AS15-40-V-T3-7PIN MSF-AS-00
Sea-Aire	Park area	Flood	LT-19132	Exterior HPS to LED	3	HPS 400	3485	ATG Electronics	AS15-40-V-T3-7PIN MSF-AS-00
Sea-Aire	Golf building	Wallpacks	LT-96754	Exterior MH to LED	2	MH 70	4100	ATG Electronics	WPDS-28-40-G3
Sunnyglen	Park area	Shoebox	LT-19132	Exterior MH to LED	3	MH 250	3485	MESTER	27V40KDT3/ SQAL04DA /JL-241C-Kit
Sunnyglen	Park area	Pumpkin heads	LT-19132	Exterior MH to LED	10	HPS 200	3485	RAB	LED5T78N/480
Sur La Brea	Park area	Flood	LT-19132	Exterior MH to LED	3	MH 400	3485	ATG Electronics	AS15-40-V-T3-7PIN MSF-AS-00
Sur La Brea	Restroom	Wallpacks	LT-96754	Exterior MH to LED	2	MH 175	4000	ATG Electronics	WPDS-60-40-G3
Sur La Brea	Tennis courts	Flood	LT-85834	Exterior MH to LED	18	MH 400	2100	ATG Electronics	AS15-40-V-T3-7PIN MSF-AS-00
Sur La Brea	Basketball court	Flood	LT-85834	Exterior HPS to LED	4	MH 400	1250	ATG Electronics	AS15-40-V-T3-7PIN MSF-AS-00
Sur La Brea	Pathway	Pumpkin heads	LT-19132	Exterior MH to LED	15	HPS 200	3485	RAB	LED5T78N/480
Victor	Outdoor kitchen area	wallpacks	LT-96754	Exterior MH to LED	1	MH 175	4000	ATG Electronics	WPDS-60-40-G3
Victor	Outdoor kitchen area	wallpacks	LT-96754	Exterior MH to LED	2	MH 250	4000	ATG Electronics	WPDS-60-40-G3
Victor	Pathway	Pumpkin head	LT-19132	Exterior HPS to LED	12	HPS 200	3485	RAB	LED5T78N/480
Walteria	Ball field	flood	LT-85834	Exterior MH to LED	4	MH 400	4000	ATG Electronics	AS15-40-V-T3-7PIN MSF-AS-00
Walteria	Table area	surface mount	LT-96754	Exterior MH to LED	4	MH 175	4000	RAB	VANLED40
Walteria	Rec building	wallpack	LT-96754	Exterior MH to LED	4	MH 175	4000	ATG Electronics	WPDS-60-40-G3

# ALED5T78N

# RAB



High output LED pole top area light with IES type V circular distribution. Wide and uniform 360 degree pattern ideal for large outdoor areas such as parking lots, corporate parks, and retail settings.

Color: Bronze

Weight: 21.8 lbs

Project:

Type:

Prepared By:

Date:

## Driver Info

Type	Constant Current
120V	0.74A
208V	0.47A
240V	0.41A
277V	0.35A
Input Watts	83.00W
Efficiency	94%

## LED Info

Watts	78.00W
Color Temp	4000K (Neutral)
Color Accuracy	73 CRI
L70 Lifespan	100,000
Lumens	8,421
Efficacy	101.5 LPW

## Technical Specifications

### Listings

#### UL Listed:

Suitable for wet locations

#### IESNA LM-79 & IESNA LM-80 Testing:

RAB LED luminaires and LED components have been tested by an independent laboratory in accordance with IESNA LM-79 and LM-80.

#### DLC Listed:

This product is on the Design Lights Consortium (DLC) Qualified Products List and is eligible for rebates from DLC Member Utilities. DLC Product Code: P00001776

### LED Characteristics

#### LEDs:

6x13W high-output, long-life LEDs

#### Lifespan:

100,000-hour LED lifespan based on IES LM-80 results and TM-21 calculations

#### Color Consistency:

3-step MacAdam Ellipse binning to achieve consistent fixture-to-fixture color

#### Color Stability:

LED color temperature is warranted to shift no more than 200K in CCT over a 5-year period

#### Color Uniformity:

RAB's range of CCT (Correlated Color Temperature) follows the guidelines of the American National Standard for Specifications for the Chromaticity of Solid State Lighting (SSL) Products, ANSI C78.377-2017.

### Construction

#### IP Rating:

Ingress Protection rating of IP66 for dust and water

#### Cold Weather Starting:

Minimum starting temperature is -40°C (-40°F)

#### Maximum Ambient Temperature:

Suitable for use in 40°C (104°F)

#### Effective Projected Area:

EPA = 1.2

#### Housing:

Precision die-cast aluminum, Type V distribution

#### Support Arms:

Extruded aluminum

#### Lens:

Clear tempered glass lens

#### Reflector:

Specular vacuum-metallized polycarbonate, Type V distribution

#### Gaskets:

High-temperature silicone

#### Finish:

Formulated for high durability and long-lasting color

#### Green Technology:

Mercury and UV free. RoHS-compliant components.



**Technical Specifications (continued)**

**Other**

**Equivalency:**  
Equivalent to 350W Pulse Start Metal Halide

**Patents:**  
The designs of the ALED5T78 are protected by patents pending in US, Canada, China, Taiwan and Mexico

**Warranty:**  
RAB warrants that our LED products will be free from defects in materials and workmanship for a period of five (5) years from the date of delivery to the end user, including coverage of light output, color stability, driver performance and fixture finish. RAB's warranty is subject to all terms and conditions found at [rablighting.com/warranty](http://rablighting.com/warranty).

**Buy American Act Compliance:**  
RAB values USA manufacturing! Upon request, RAB may be able to manufacture this product to be compliant with the Buy American Act (BAA). Please contact customer service to request a quote for the product to be made BAA compliant.

**Power Factor:**  
99.2% at 120V, 90.6% at 277V

**Drivers (3):**  
Constant Current, 720mA, Class 2 with 6kV surge protection, 100-277VAC, 50/60 Hz

**Optical**

**BUG Rating:**  
B3 U1 G1

**Electrical**

**THD:**  
7% at 120V, 16.4% at 277V

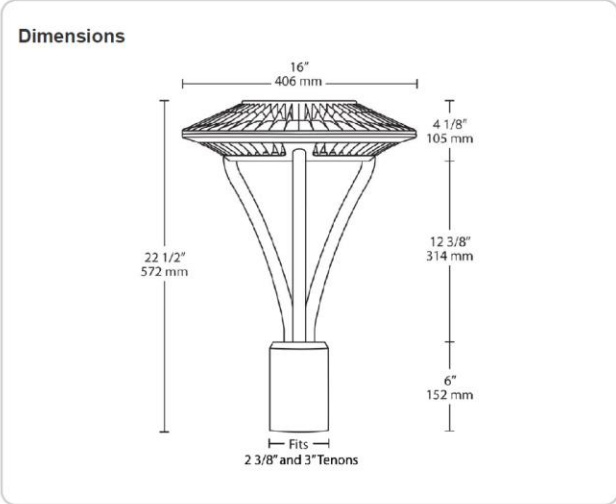

- Features**
- IES type V (circular) distribution
  - 100,000-hour LED lifespan
  - Compatible with standard 2 3/8" and 3" tenons
  - "Air-Flow" fins for maximum heat dissipation
  - 5-Year, No-Compromise Warranty

**Ordering Matrix**

Family	Distribution	Wattage	Color Temp	Finish	Driver Option	Options	Other Options
ALED	5T	78	N				
	5T = Type V	26 = 26W 52 = 52W 78 = 78W	Blank = 5000K (Cool) N = 4000K (Neutral) Y = 3000K (Warm)	Blank = Bronze W = White K = Black RG = Gray	Blank = 120-277V /D10 = Dimmable /BL = Bi-Level /480 = 480V /480/D10 = 480V w/ Dimmable	Blank = No Option /LC = Lightcloud Controller /PCT = 120-277V Twistlock Photocell /PCT4 = 480V Twistlock Photocell	USA = BAA Compliant Blank = Standard



# BOS, BOF, BOQ Oceanside Bollard

## Outdoor

The Oceanside Bollard is the LED alternative to traditional bollard lighting, which illuminates pathways, parking structures, or any kind of commercial real estate. The Oceanside Bollard is available in Dome, Flat Top, or Square design.

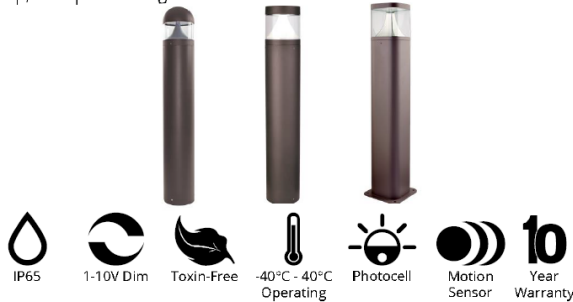

Luminaire	Oceanside Dome Bollard	Type
Project		
Product		
Notes		

- Features**
- IP65 Silicon Gasket
  - Can be cut to custom lengths
  - High Purity Aluminum



### Order Format

Sample: BOS-25-40-ND-G2

Series	Wattage	CCT	Voltage	Dimming	Generation	Finish Color
BOS=Oceanside Dome Bollard BOF=Oceanside Flat Bollard BOQ=Oceanside Square Bollard	25=25W 30=30W	40=4000K 50=5000K	Blank=100-277V V=347-480V	Blank=1-10V Dimming ND=Non-Dimming	G2	Blank=ATG Bronze Custom Available

### Application

The luminaire comes standard with a bolt mounting kit. The Oceanside Bollard can also be cut to custom lengths upon request.



### Construction

ATG's Oceanside Bollard is built from high-purity aluminum. The housing features integral thermal management and is IP65 rated for stellar protection from the elements. Operating ambient temperature ranges from -40°C to +40°C.



### Electrical

The Oceanside bollard produces 1650 LM of light output. The fixture operates at a standard voltage of 100-277V and draws 25W of power. L70 is rated for 50,000 hours, or approximately 11.5 years at 12 hours a day of operation. Photocell sensors and dimming controls may further increase efficiency and fixture longevity.

### Optics

These fixtures feature a clear prismatic borosilicate glass refractor for precise illumination. Round models have a clear PC lens while square models feature a diffusion PC lens. Available CCT options are 4000K and 5000K.

### Certifications

- CE
- RoHS
- Title 24
- IP65 rated

<b>Input Voltage (VAC)</b>	100-277
<b>CRI</b>	80
<b>CCT(K)</b>	4,000, 5,000
<b>PF</b>	>.9
<b>THD</b>	<20%
<b>L70 (Hours)</b>	50,000
<b>Color</b>	Bronze, Black
<b>Housing</b>	High Purity Aluminum
<b>Optic Types</b>	Type V
<b>Lens</b>	Clear PC, Diffusion PC
<b>Temperature Range</b>	-40°C to 40°C
<b>Warranty</b>	10 Years

Lumen Data							Mounting		
	4K		Catalog Number	Shape	Wattage (W)	System Wattage	Efficacy (Lm/W)	Lumens (Lm)	<b>Bolt Mount Installation Template</b>  <b>Round</b>          <b>Square</b>
	BOS-25-40	✓	Dome	25W	25	66	1,650		
	BOF-25-40	✓	Flat	25W	25	66	1,650		
BOQ-30-40	✓	Square	30W	30	63	1,900			
	5K		Catalog Number	Shape	Wattage (W)	System Wattage	Efficacy (Lm/W)	Lumens (Lm)	
	BOS-25-50		Dome	25W	25	66	1,650		
	BOF-25-50		Flat	25W	25	66	1,650		
BOQ-30-50		Square	30W	30	63	1,900			
							<b>Stock Item</b> ATG Core Product		

Dimensions						
<b>25W Dome</b>  <b>26.5W Flat</b>			<b>30W Square</b>			
	Part No.	Length (L)		Diameter (D)	Part No.	Length (L)
BOS-25	39.37"	6.61"	BOQ-30	39.37"	6.61"	8.85"
BOF-25	39.37"	6.61"	Recorded in inches			

## 10 Year Warranty

ATG Electronics®  
Industry Leading 10 Year Limited Warranty  
For North American LED Lighting Fixtures

ATG Electronics warrants to the original purchaser of ATG Electronics Domestic LED products listed above that were manufactured for which the ATG Electronics Spec Sheet located on our website contains the words "10 year limited warranty" that, subject to the below terms and conditions of this warranty, when such LED products are properly installed they will comply with ATG Electronics published product specifications for such products and will be free from material defects in material and workmanship for a period of ten (10) years from the date of sale by ATG Electronics, or, if lesser, 50,000 hours of operation (at an average of 13.6 hours per day operation). The LED arrays in the Product(s) will be considered defective in material or workmanship only if a total of 15% or more of the individual light emitting diodes in the Product(s) fail to illuminate.

The above express limited warranty is extended by ATG Electronics® only to the original or first end-user purchaser and only for the original installed location. This warranty only applies to products purchased after June 1, 2017. This warranty is non-transferrable, whether by assignment or operation of law. The original purchaser must provide warranty claims to ATG Electronics within the warranty period promptly upon discovery and in accordance with ATG Electronics Return and Repair Procedures as outlined within this document.

Should any defects be found by ATG Electronics upon its inspection of the properly returned product, ATG Electronics sole responsibility and liability under this warranty will be, at its option, to either repair or replace the defective part or parts or else make available a new replacement unit that will provide equal or better performance. All decisions regarding the existence or non-existence of defects or otherwise affecting the warranty shall be made by ATG ELECTRONICS and shall be final and binding on all parties. Where a defective LED product is replaced under this warranty, the balance of the original warranty period shall remain effective.

### Conditions and Exclusions

This warranty is conditioned upon proper installation, use and maintenance. This warranty will automatically become null and void and shall not be applicable to any LED fixture which (i) has not been timely paid for, (ii) is not installed and operated in accordance with the current edition of The National Electric Code (NEC), the Standards for Safety of Underwriters' Laboratory, Inc. (UL) or with ATG Electronics instructions and guidelines, (iii) has been moved from its original installation, (iv) has been installed within an area that has exposure to sulfur or any area with high acidic compounds in use, (v) has been operated in an ambient temperature or humidity that is higher than 35 degrees Celsius, (vi) has been subjected to a lightning strike, power surge or overvoltage condition, (vii) has its LED Board subjected to static electricity due to failure to discharge same prior to connecting or disconnecting the lead from the LED board, (viii) was not installed and/or operated in accordance with ATG Electronics instructions and guidelines, (ix) has been mishandled, misused, abused, tampered with, modified or altered by anyone other than ATG ELECTRONICS, (x) has been subjected to abnormal stresses and operating conditions, or (xi) has been operated without overvoltage and lightning protection devices in place.

### Limitations

#### Disclaimers & Limitations of Liability

The foregoing warranty is exclusive of all other statutory, written or oral warranties and no other warranties of any kind, statutory, by operation of law or course of performance, or otherwise, are given, herein expressed or otherwise received. EXCEPT AS EXPRESSLY PROVIDED ABOVE, ATG ELECTRONICS DISCLAIMS ALL REPRESENTATIONS, WARRANTIES AND CONDITIONS OF ANY KIND, EXPRESS OR IMPLIED, REGARDING THE LED PRODUCTS AND ITS SERVICES, INCLUDING, WITHOUT LIMITATION, THE IMPLIED WARRANTIES OF MERCHANTABILITY AND FITNESS FOR A PARTICULAR USE OR PURPOSE.

**LIMITATION OF LIABILITY.** Other than the obligation to repair or replace as provided above, ATG Electronics shall have no liability for any losses, expenses or damages as a result of the installation, use, inability to use, removal or replacement of any LED product. ATG Electronics will not under any circumstances whether as a result of breach of contract, breach of warranty, tort, strict liability or otherwise be liable for consequential, incidental, special or exemplary damages including but not limited to, loss of profits or revenues, loss of any other goods or associated equipment or damage to any associated equipment, cost of capital, cost of substitute products, facilities or services, down time cost or claims of claimant's customers. ATG Electronics liability on any claim of any kind for any loss or damages arising out of, resulting from or concerning any LED product, any aspect of this warranty or for any products or services furnished hereunder shall not exceed the price of the fixture which gives rise to the claim.

### Return and Repair Procedures

All warranty requests and or questions are to be directed to ATG Electronics Customer Service Department (CSD) at 888-618-7298. If deemed necessary, the CSD will issue a Returned Merchandise Authorization (RMA) number which must be included on both the packing slip of the component or fixture being returned and on the outside of the box. You must include your name and contact information, including your email address, on the packing slip so that we can contact you easily. Each component or fixture must be packaged very carefully and properly so as to prevent damages in shipment and must be shipped freight prepaid. Please obtain a proof of delivery to ensure that the material is received.

Once the component or fixture has been received and tested, an evaluation report will be provided to the end user via email. This report will clarify the following:

- A) The component / fixture is covered under the warranty policy and will either be repaired or replaced.
- B) The component / fixture is not covered under the warranty policy and the reason for this determination.

If ATG ELECTRONICS determines that the component or fixture is covered under the warranty, then the appropriate repairs will be started or a replacement fixture will be manufactured and shipped. Please note that in the event the returned component or fixture is found not to be covered under this warranty, you may be subject to a labor charge for the evaluation process and will be responsible for all return shipping charges and fees. For components and fixtures determined to be covered under this warranty prior to the first anniversary of the Sale Date, the repaired or replacement component or fixture will be returned to you at no charge. You will be responsible for all other shipping charges.

### No Labor Reimbursement

All components and fixtures determined to be covered by this warranty as provided above, will be repaired or replaced at no charge to the customer, however, except as expressly provided above with respect to recessed and linear fixtures during the first year, the customer must hire and pay for an electrician to remove and reinstall such components and fixtures. No labor costs will be covered for the removal or reinstallation of any components or fixtures. The warranty does not cover modifications, repairs or replacements, or the related labor or materials costs, that may be necessary to facilities or third party products in connection with the removal, repair, or replacement of any LED product under this warranty.

# VANLED40



Low-profile vandal-resistant fixture covers the footprint of most traditional canopy lights. Available in flat or drop lens with frosted and unfrosted options.

Color: Bronze

Weight: 10.3 lbs

Project:

Type:

Prepared By:

Date:

### Driver Info

Type	Constant Current
120V	0.35A
208V	0.2A
240V	0.18A
277V	0.16A
Input Watts	39.90W
Efficiency	N/A

### LED Info

Watts	40.00W
Color Temp	5000K (Cool)
Color Accuracy	84 CRI
L70 Lifespan	100,000
Lumens	5,380
Efficacy	134.8 LPW

## Technical Specifications

### Listings

#### UL Listed:

Suitable for Wet Locations. Covered Ceiling Mount Only.

#### IESNA LM-79 & LM-80 Testing:

RAB LED luminaires and LED components have been tested by an independent laboratory in accordance with IESNA LM-79 and LM-80.

#### DLC Listed:

This product is listed by Design Lights Consortium (DLC) as an ultra-efficient premium product that qualifies for the highest tier of rebates from DLC Member Utilities. DLC Product Code: PHYBQJS

### LED Characteristics

#### LEDs:

Long-life, high-efficacy surface-mount LEDs

#### Color Stability:

RAB LEDs exceed industry standards for chromatic stability

#### Color Uniformity:

RAB's range of CCT (Correlated Color Temperature) follows the guidelines of the American National Standard for Specifications for the Chromaticity of Solid State Lighting (SSL) Products, ANSI C78.377-2017.

### Construction

#### Maximum Ambient Temperature:

Suitable for use in 40°C (104°F)

#### Cold Weather Starting:

Minimum starting temperature is -40°C (-40°F)

#### Lens:

Vandal-resistant polycarbonate textured opaque for low glare drop lens

#### Housing:

Die-cast aluminum housing and lens frame with (4) 1/2" NPS side conduit entries and weatherproof rear wire plug and access plate

#### Mounting:

Ceiling mount to recessed junction with knockout template or directly to ceiling surface, utilizing side conduit entry points

#### IP Rating:

Ingress Protection rating of IP66 for dust and water

#### Air Tight:

Housing certified Air Tight as per ASTM E283

#### Finish:

Our environmentally friendly polyester powder coatings are formulated for high-durability and long-lasting color

### Other

#### Warranty:

RAB warrants that our LED products will be free from defects in materials and workmanship for a period of five (5) years from the date of delivery to the end user, including coverage of light output, color stability, driver performance and fixture finish. RAB's warranty is subject to all terms and conditions found at [rablighting.com/warranty](http://rablighting.com/warranty).

#### Buy American Act Compliance:

RAB values USA manufacturing! Upon request, RAB may be able to manufacture this product to be compliant with the Buy American Act (BAA). Please contact customer service to request a quote for the product to be made BAA compliant.

### Electrical

#### Driver:

Class 2, Constant Current, 120-277V, 50-60Hz, 120V: 0.35A, 208V: 0.2A, 240V: 0.18A, 277V: 0.16A

#### THD:

8.33% at 120V, 7.24% at 277V

#### Power Factor:

99.8% at 120V, 94.8% at 277V

# VANLED40



### Dimensions

### Features

- Fits the footprint of older canopy lights
- Vandal resistant and UV resistant lens
- Ultra-high efficiency
- Clean, contemporary, low-profile design
- Available with drop lens or flat lens
- IP66 rated, keeps dust, bugs and water out
- Photo and motion sensor options available

### Ordering Matrix

Family	Wattage	Color Temp	Lens-Optics	Finish	Voltage	Options	Suffix
VANLED	40						
	10 = 10W 20 = 20W 28 = 28W 40 = 40W 52 = 52W 65 = 65W 75 = 75W	Blank = 5000K (Cool) N = 4000K (Neutral) Y = 3000K (Warm)	Blank = Drop lens F = Flat lens <sup>1</sup> FR = Frosted Drop Lens FFR = Frosted Flat Lens <sup>1</sup>	Blank = Bronze W = White	Blank = 120-277V, 0-10V Dim Standard /480 = 480V, 0-10V Dim Standard	Blank = No Options /MVS = Microwave Sensor <sup>1</sup> /WS = Wattstopper, 8ft /WS2 = Wattstopper, 20ft /PCS = 120V Swivel Photocell /PCS2 = 277V Swivel Photocell /PCS4 = 480V Swivel Photocell /LC = Lightcloud® Control factory Installed /E2 = Emergency Battery, 120-277V only	Blank = Standard USA = Complies with the BAA

<sup>1</sup> /MVS option not available with F and FFR lens

**WALLMAX™ OPEN FACE**  
WP-OP Series



**DIMENSIONS:**

SIZE 1 - 28W & 40W

SIZE 2 - 28W, 40W, 50W, 80W & 120W

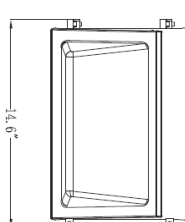
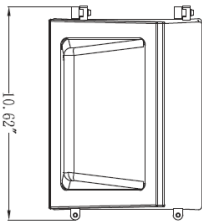
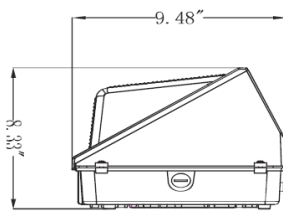
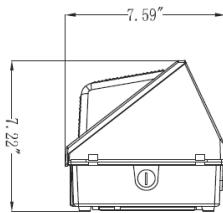

**PRODUCT DESCRIPTION:**

WallMax™ Open Face Wall Packs are ideal for brightly-lit outdoor environments in parking garages, entrances, public areas, schools, hospitals, hotels and outdoor walkways nationwide. The 28-, 40-, 50-, 80-, and 120-watt LED fixtures are energy-efficient replacements for up to 750-watt metal halide fixtures. The fixtures are rebatable, save energy, generate lower maintenance costs, and prevent light pollution.

**FEATURES:**

- Heavy-duty cast aluminum housing is polyester powder coated to be rust and corrosion proof
- High-quality shatter-resistant glass
- Impact resistant borosilicate glass
- 0-10V dimming driver standard
- 6kV integral surge suppression standard
- Six ½ NPS knockouts available
- Photo/Motion Sensor, 347-480V, Battery Back-Up options, Visors and Wire Guards available.

**CONTROLS:**

**120-277VAC Photocontrol:**

- Power the fixture when light levels reach 20 lux or below
- Turn off the fixture at 30 lux or higher

**PIR Outdoor Daylight/Motion Sensor:**





- Sensor provides multi-level control based on motion and/or daylight contribution for 0-10V DC Drivers
- All control parameters are adjustable remotely
- At least one FSIR-100 remote control must be ordered per project to be able to adjust factory settings for daylight / motion sensor
- For more information, please see supplementary datasheet for sensor model **MSWSFSP221B>>>**

**WARRANTY:**

10-year standard warranty with labor allowance\* (further details available at [www.maxlite.com/warranties](http://www.maxlite.com/warranties))  
\*Warranty Limitations: Product must be rated for the application per the Product Data Sheet (PDS); operated ≤16 hrs/day; in ambient of -29°F to 104°F.  
\*Up to \$25/unit; labor allowances of up to \$500/unit available for purchase – contact MaxLite representative for details.

MODEL SELECTION		Typical order example: WP-OP28U-50B				
WP-OP			-		B	
FAMILY	WATTAGE	VOLTAGE	-	LED MODULE	FINISH	OPTION
WP-OP= Open Face Wall Pack	28= 28W, 150W MH replacement 40= 40W, 175W MH replacement 50= 50W, 250W MH replacement 80= 80W, 400W MH replacement 120= 120W, 750W MH replacement	U= 120-277V H= 347-480V	-	40= 4000K, CRI 80+ 50= 5000K, CRI 80+	B= Bronze <i>Contact Maxlite for additional finishes</i>	(BLANK)= None PC= 120-277V Photocontrol MS= PIR Daylight/Motion Sensor L= Size 2 housing EM2= Size 2 housing, Battery Backup, -20° C EM0= Size 2 housing, Battery Backup, 0° C

1. Not DLC listed. Not available with LEM2 or LEM0 options.  
2. Motion Sensor performs at 20' up to 48" diameter. External model MSWSFSP221B-D will be provided on models with 120W; 347-480V; or -20 C Battery back up.  
3. Use with 28W and 40W fixtures only.  
4. Option L must be used with options EM0 and EM2 for all wattages.

ACCESSORIES			
ORDER CODE	MODEL NUMBER	DESCRIPTION	ACCESSORIES IMAGE
100679	WP-OP-S1PI ATF-B	Beauty Plate, 14.50" X 9.50" X 0.08", Size 1, Bronze, 28W and 40W Models	
100461	WP-OP-S2PI ATF-B	Beauty Plate, 18.1" * 8.7" * 0.08", Size 2, Bronze, 50W, 80W, and 120W Models	
102184	FSIR-100	Remote Control for daylight / motion sensor	
100821	WP-OP-S1VISOR-B	Cutoff Visor, Size 1, Bronze, 28W and 40W models	
100822	WP-OP-S2VISOR-B	Cutoff Visor, Size 2, Bronze, 50W, 80W and 120W models	
14099860	WP-OPSWG	Wire Guard, Size 1, Bronze, 28W and 40W models	
101499	WP-OPLWG	Wire Guard, Size 2, Bronze, 50W, 80W and 120W models	

**SPECIFICATIONS:**

		28W	40W	50W	80W	120W
ITEM	SPECIFICATION	DETAILS				
<b>GENERAL PERFORMANCE</b>	Input Power (W)	28	40	50	80	120
	Lumens Delivered (up to)	3,770	5,645	7,065	11,375	16,945
	Efficacy (up to)	136	138	138	140	140
	CRI	≥80				
	Lumen Maintenance (L85, TM-21 @ 25°C)	>100,000 hours				
	Color Temperature	4000K, 5000K				
	Spacing Criteria	Available upon request				
<b>ELECTRICAL</b>	Input Voltage	120-277V standard; 347-480V available				
	Power Factor	>90%				
	THD	<15%				
<b>PHYSICAL</b>	Housing	Die-Cast Polyester Aluminum				
	Mounting	Fits electrical box or mount directly				
<b>QUALIFICATION</b>	Qualification	DLC Premium, ETL, IP65				
	Environment	Outdoor, wet location				
	Warranty	10-year standard warranty*				
	Operating Temperature	-40°F ~ 104°F (-40°C ~ 40°C)				
	Humidity	10%-90% RH, non-condensing				

Lighting layouts and spacing criteria available upon request.



**LAYOUTS:**

**WP-OP 28W:**

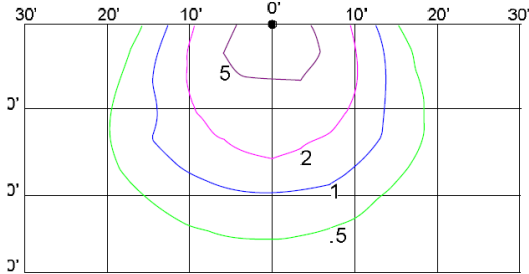

**28W**  
**3,640 LUMENS (SIZE 1 HOUSING)**  
**10' MOUNTING HEIGHT**

FOOT-CANDLE CORRECTION FACTOR:

NEW HEIGHT:	10'	15'	20'	25'
MULTIPLY BY:	1	0.67	0.50	0.40

**WP-OP 40W:**

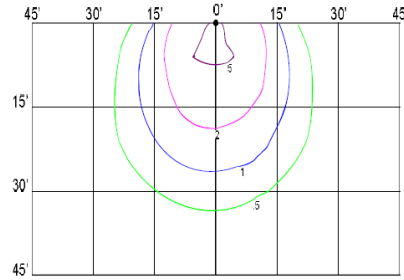

**40W**  
**5,540 LUMENS (SIZE 1 HOUSING)**  
**15' MOUNTING HEIGHT**

FOOT-CANDLE CORRECTION FACTOR:

NEW HEIGHT:	10'	15'	20'	25'
MULTIPLY BY:	1.50	1	0.75	0.60

**WP-OP 50W:**

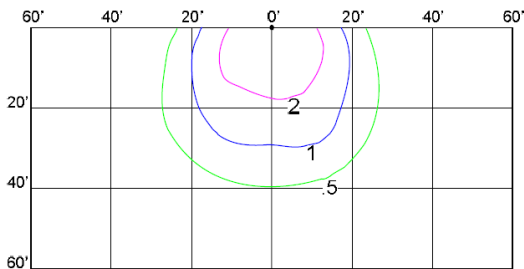

**50W**  
**7,065 LUMENS**  
**20' MOUNTING HEIGHT**

FOOT-CANDLE CORRECTION FACTOR:

NEW HEIGHT:	10'	15'	20'	25'
MULTIPLY BY:	2	1.33	1	0.80

**WP-OP 80W:**

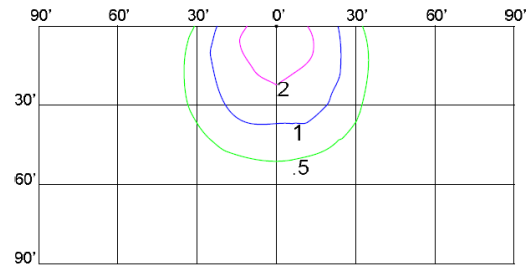

**80W**  
**11,375 LUMENS**  
**30' MOUNTING HEIGHT**

FOOT-CANDLE CORRECTION FACTOR:

NEW HEIGHT:	10'	15'	20'	25'	30'
MULTIPLY BY:	3	2	1.50	1.2	1

**WP-OP 120W:**

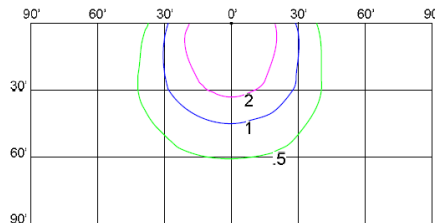

**120W**  
**16,945 LUMENS**  
**30' MOUNTING HEIGHT**

FOOT-CANDLE CORRECTION FACTOR:

NEW HEIGHT:	10'	15'	20'	25'	30'
MULTIPLY BY:	3	2	1.50	1.2	1





MaxLite > Products > Outdoor > Wall Luminaires > WallMax Open Face > WP-OP50U-40B

**WP-OP50U-40B**

Order# 100535



**Features**

- Heavy-duty cast aluminum housing with corrosion resistant powder coat finish
- Borosilicate glass standard
- 0-10V dimming driver, 6kV surge suppression standard
- Photo/motion sensor, 347-480V, battery back-up options, visors and wire guards available
- Sealed fixture is dirt and bug free
- 10 Year Limited Warranty
- Six 1/2 NPS conduit holes all sides to accommodate surface conduit

[Find a Distributor](#)

**Performance**

Input Wattage	50.0
Input Voltage Range (V)	120-277
Delivered Lumens (lm)	7065
Efficacy (lm/W)	135.0
Color Rendering Index (CRI)	80
Color Temperature (CCT)	4000
Equivalent Wattage	250W MH
Beam Angle	0
Power Factor	0.90
MAX THD (%)	0
Min. Ambient Temp (°F)	-22
Max. Ambient Temp (°F)	104

**Validations and Downloads**

- Data Sheet [Download](#)
- Owner Manual [Download](#)
- .ies [Download](#)
- ETL [ETL Listed](#)

**Dimming Control**

0-10V Dimming Y

**Dimensions**

Product Weight (lbs.)	10.36
Product Height (Inches)	9.48
Product Length (Inches)	8.33
Product Width (Inches)	14.60

**Longevity**

L70 Life (Hours)	100000
Warranty (Years)	10

**Qualifications**

DLC Premium

**AVAILABLE ACCESSORIES (SOLD SEPARATELY)**

Image	Item #	Order #	Description
	FSIR-100	102184	REMOTE HANDHELD CONFIGURATION TOOL (FOR USE WITH FSP-211 AND FSP-221 SENSORS)
	WP-OP-S1PLATE-B	100679	BEAUTY PLATE FOR OPEN FACE WALL PACKS. 14.5IN X 9.50IN X 0.08IN. SIZE 1. BRONZE. COMPATIBLE WITH 28W AND 40W MODELS

	WP-OP-S1VISOR-B	100821	CUTOFF VISOR FOR OPEN FACE WALL PACKS, SIZE 1, BRONZE, COMPATIBLE WITH 28W AND 40W MODELS
	WP-OP-S2PLATE-B	100461	BEAUTY PLATE FOR OPEN FACE WALL PACKS, 18.1IN X 8.70IN X 0.08IN, SIZE 2, BRONZE, COMPATIBLE WITH 50W, 80W, 120W MODELS
	WP-OP-S2VISOR-B	100822	CUTOFF VISOR FOR OPEN FACE WALL PACKS, SIZE 2, BRONZE, COMPATIBLE WITH 50W, 80W, AND 120W MODELS
	WP-OPLWG	101499	WIRE GUARD FOR OPEN FACE WALL PACK, SIZE 2, COMPATIBLE WITH 50W, 80W, 120W MODELS
	WP-OPSWG	14009860	WIRE GUARD FOR OPEN FACE WALL PACK, SIZE 1, COMPATIBLE WITH 28W AND 40W MODELS

### Product Microsites



[Terms of Use](#) | 
 [Site Map](#) | 
 [Contact Us](#) | 
 [Mobile](#)  
 © Copyright 2011-2019, MaxLite, Inc. All Rights Reserved.

## Specifications

### Construction:

- Rugged one-piece, die-cast aluminum housing secures the thermally conductive LED panel and electrical chamber
- Low profile, 3G vibration rated compact design minimizes wind load requirements.
- Housing is completely sealed against moisture and environmental contaminants.

### Optics:

- Available in IES Type III, IV, V distributions
- Light engines are available in standard 4000 K and 5000 K (70 CRI) configurations.
- Scalable Lumen Packages from 5,360 to 42,000 Lumens replaces up to 1000W Metal Halide.
- Optics is precisely designed to shape the distribution, maximizing efficiency and application spacing.
- For the ultimate level of spill light control, an optional house-side shield accessory can be field or factory installed.
- The optics can conform to dark sky requirement.

### Electrical:

- Universal 120-277 VAC or 347-480 VAC input voltage
- Standard with 1-10V dimming driver(s)
- THD: ≤20%
- Power Factor: ≥90%

### Controls:

- Optional occupancy sensor
- Optional Photocell

### Ambient Temperature:

- Ambient operating temperature -40° C to 45° C (-40° F to 113° F).

### Installation:

- Suitable for mounting heights ranging from 26-50' in area lighting applications
- Round pole, Square pole, slipfitter and wall mount are available
- The design can be operated by one person to install the whole lamp

### Lifespan:

- Estimated 100,000-hour LED lifespan based on IES LM-80 results and TM-21 calculations

### Finish:

- It's available in black or optional dark bronze, silvery gray or white.



### Certifications:

- UL wet location listed and DLC qualified

Small Size: 40W/70W/100W

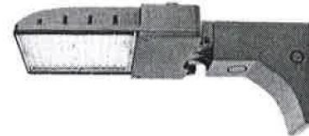

Medium Size: 150W/200W

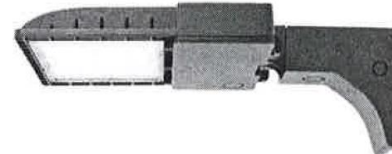

Large Size: 250W/300W



### Warranty:

Mester warrants that our LED products will be free from defects in materials and workmanship for a period of five (5) years from the date of delivery to the end user, including coverage of light output, color stability, driver performance and fixture finish. (For more information visit: <http://www.mesterleds.com/resources/warranty/>)

### Note:

Actual performance may differ as a result of end-user environment and application. All values are design or typical values, measured under laboratory conditions at 25°C (±5°C) specifications subject to change without notice.

## Applications:

Auto dealerships, parking lots, walkways, roadways, campuses, facade lighting, grocery stores and other public areas.

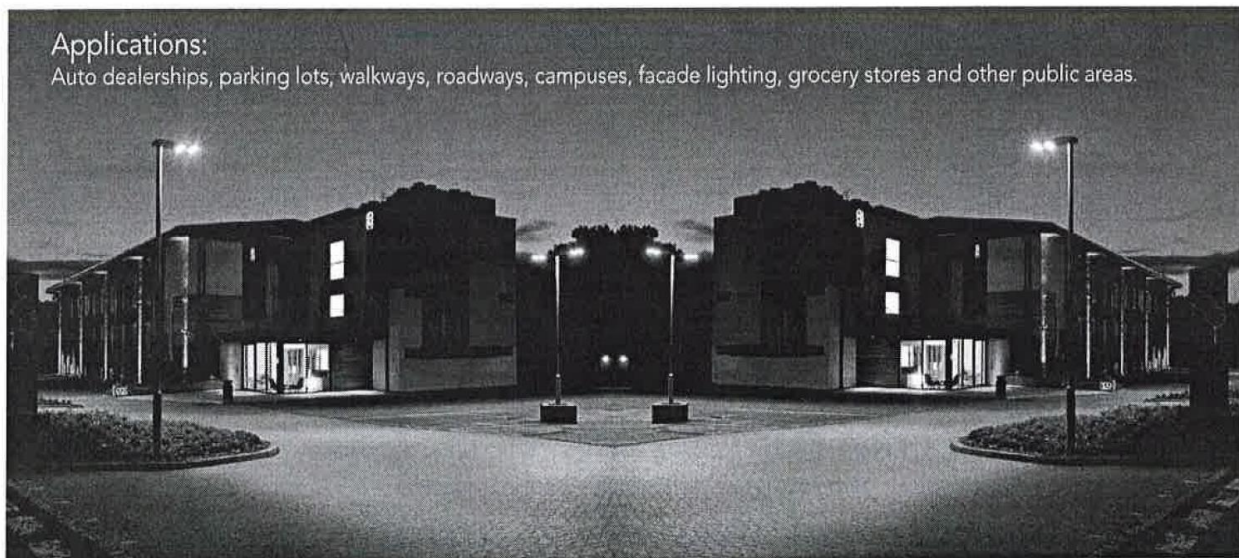



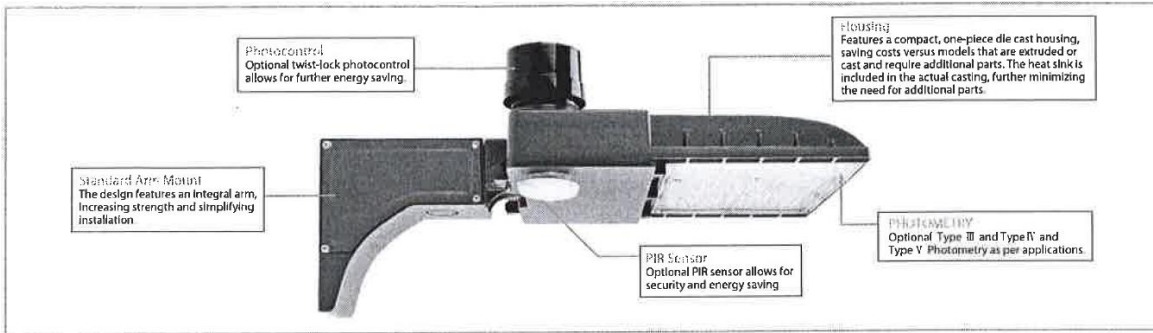







**PERFORMANCE DATA**

SYSTEM WATTS	VOLTAGE	DIST. TYPE	4000K(70CRI)		5000K(70CRI)	
			LUMENS	LPW	LUMENS	LPW
40W	120-277V	3	5400lm	135 lm/W	5500lm	138 lm/W
	120-277V	4	5360lm	134 lm/W	5480lm	137 lm/W
	120-277V	5	5600lm	140 lm/W	5720lm	143 lm/W
45W	347-480V	3	5900lm	131 lm/W	6000lm	133 lm/W
	347-480V	4	5850lm	130 lm/W	5940lm	132lm/W
	347-480V	5	6120lm	136 lm/W	6210lm	138 lm/W
70W	120-277V	3	9500lm	136 lm/W	9600lm	137 lm/W
	120-277V	4	9310lm	133 lm/W	9450lm	132 lm/W
	120-277V	5	9730lm	139 lm/W	9800lm	140 lm/W
75W	347-480V	3	9800lm	131 lm/W	10000lm	133 lm/W
	347-480V	4	9750lm	130 lm/W	9900lm	132 lm/W
	347-480V	5	10200lm	136 lm/W	10350lm	138 lm/W
100W	120-277V	3	13500lm	135 lm/W	13800lm	138 lm/W
	120-277V	4	13200lm	132 lm/W	13300lm	133 lm/W
	120-277V	5	13800lm	138 lm/W	13900lm	139 lm/W
150W	120-277V	3	20500lm	137 lm/W	20800lm	139 lm/W
	347-480V	3	21000lm	140 lm/W	21300lm	143 lm/W
	120-277V/347-480V	4	19800lm	132 lm/W	20000lm	133 lm/W
	120-277V	5	20500lm	137 lm/W	20800lm	139 lm/W
	347-480V	5	21000lm	140 lm/W	21000lm	140 lm/W
200W	120-277V/347-480V	3	25500lm	128 lm/W	26000lm	130 lm/W
	120-277V/347-480V	4	24600lm	123 lm/W	24800lm	124 lm/W
	120-277V/347-480V	5	25500lm	128 lm/W	26000lm	130 lm/W
250W	120-277V/347-480V	3	34000lm	136 lm/W	34500lm	138 lm/W
	120-277V/347-480V	4	33250lm	133 lm/W	33750lm	135 lm/W
	120-277V/347-480V	5	34750lm	139 lm/W	35250lm	141 lm/W
300W	120-277V	3	40500lm	135 lm/W	41000lm	137 lm/W
	347-480V	3	41500lm	138 lm/W	42000lm	140 lm/W
	120-277V/347-480V	4	39600lm	132 lm/W	39900lm	133 lm/W
	120-277V	5	40500lm	135 lm/W	41000lm	137 lm/W
	347-480V	5	41500lm	138 lm/W	42000lm	140 lm/W

**ELECTRICAL DATA**

Number Of Drivers	Driver Current (mA)	Nominal Power (W)	INPUT VOLTAGE (V)	CURRENT (Amps)
1	980	40	120	0.33
		40	208	0.19
		40	240	0.17
		40	277	0.14
		45	347	0.13
		45	480	0.09
1	1720	70	120	0.58
		70	208	0.34
		70	240	0.29
		70	277	0.25
		75	347	0.22
		75	480	0.16
1	2450	100	120	0.83
		100	208	0.48
		100	240	0.42
		100	277	0.36
		150	120	1.25
		150	208	0.72
1	3900	150	240	0.63
		150	277	0.54
		150	347	0.43
		150	480	0.31
		200	120	1.67
		200	208	0.96
1	5100	200	240	0.83
		200	277	0.72
		200	347	0.58
		200	480	0.42
		250	120	2.08
		250	208	1.20
1	6400	250	240	1.04
		250	277	0.90
		250	347	0.72
		250	480	0.52
		300	120	2.50
		300	208	1.44
1	6000	300	240	1.25
		300	277	1.08
		300	347	0.86
		300	480	0.63

## EPA OF AREA LIGHT

Item							
	1	2 @90°	2 @120°	2@180°	3 @90°	3 @120°	4 @90°
40W/70W/100W	0.3413	0.5929	0.7983	0.6826	1.0239	1.0499	1.0239
150W/200W	0.423	0.735	0.873	0.846	1.158	1.185	1.158
250W/300W	0.4759	0.7889	1.0581	0.9518	1.2648	1.3711	1.2648

## BUG

SYSTEM WATTS	VOLTAGE	DIST. TYPE	B	U	G
40W	120-277V	3	1	0	1
45W	347-480V	3	1	0	1
70W	120-277V	3	2	0	2
75W	347-480V	3	2	0	2
100W	120-277V	3	2	0	2
150W	120-277V/347-480V	3	3	0	3
200W	120-277V/347-480V	3	3	0	3
250W	120-277V/347-480V	3	4	0	4
300W	120-277V/347-480V	3	4	0	4

## MOUNTING

- Standard versatile mounting arm accommodates multiple drilling patterns as well as square and round poles
- Wall Mount available for direct wall mounting and J-box mounting
- Optional for cast aluminum slipfitter mounting adapter (Compatible with more MESTER mounting adaptors such as Tenon, suits for various application)

### Mounting Options



**Arm Mount** (4" and 5" Square and Round poles)  
Standard versatile mounting arm is simple to install and can be used with existing poles for retrofit installations.



**Slipfitter Mount**  
An optional cast aluminum mast arm adapter secures fixture head to nominal 2" (2-3/8" O.D. pipe size) horizontal steel tenon arm.

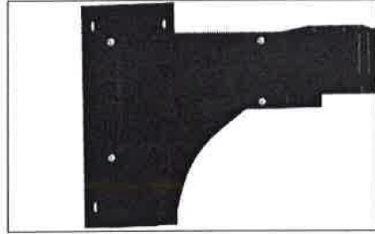

**Wall Mount**  
Wall Mount is easy to install for direct wall mounting with 1/2" conduit wiring or standard J-box mounting

### Mounting Dimensions

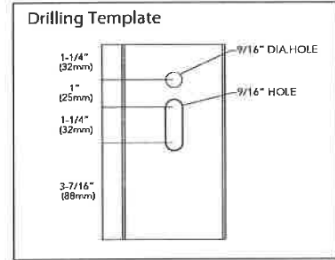
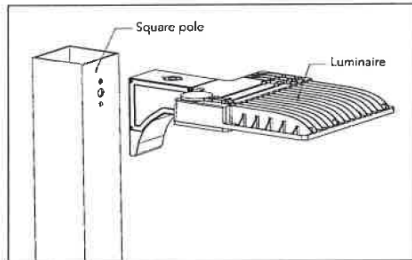
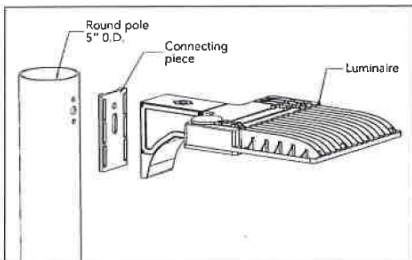

# ADDITIONAL MOUNTING ACCESSORIES

POLE BRACKET * For mounting one fixture on an existing pole			
	<p><b>4\" Square Pole Mount with 2-3/8\" O.D. Tenon</b>                      NO. 4SQ-SP-D                      Finish: Dark Bronze                      USE: For use with square, non-tapered steel and aluminum poles. Furnished with four 5/16\" hex head stainless-steel bolts. Vertical tenon measures 2-3/8\" O.D., and is made of steel tubing. Fixtures mounted to this bracket can be adjusted both vertically and horizontally.</p>		<p><b>4\" Round Pole Mount with 2-3/8\" O.D. Tenon</b>                      NO. 4SOR-SP-D                      Finish: Dark Bronze                      USE: For use with Round, non-tapered steel and aluminum poles. Furnished with three 3/8\" hex head stainless-steel bolts. Vertical tenon measures 2-3/8\" O.D., and is made of steel tubing. Fixtures mounted to this bracket can be adjusted both vertically and horizontally.</p>
	<p><b>5\" Square Pole Mount with 2-3/8\" O.D. Tenon</b>                      NO. 5SQ-SP-D                      Finish: Dark Bronze                      USE: For use with square, non-tapered steel and aluminum poles. Furnished with four 5/16\" hex head stainless-steel bolts. Vertical tenon measures 2-3/8\" O.D., and is made of steel tubing. Fixtures mounted to this bracket can be adjusted both vertically and horizontally.</p>		<p><b>5\" Round Pole Mount with 2-3/8\" O.D. Tenon</b>                      NO. 5SOR-SP-D                      Finish: Dark Bronze                      USE: For use with Round, non-tapered steel and aluminum poles. Furnished with three 3/8\" hex head stainless-steel bolts. Vertical tenon measures 2-3/8\" O.D., and is made of steel tubing. Fixtures mounted to this bracket can be adjusted both vertically and horizontally.</p>
	<p><b>Pole Bracket accessories-Tenon &amp; Yoke Adaptor</b>                      NO. SP-TR-D                      Finish: Dark Bronze                      USE: The 2-3/8\" OD Tenon Mount Adaptor for Yoke Fixtures is designed to mount MESTER light fixtures that are equipped with a yoke mount onto a 2-3/8\" OD tenon. It may be utilized with the Mester Flood Light Series of light fixtures.</p>		
WALL BRACKET * Attaches to any flat surface * Provides wiring access		Mid-Pole tenon Bracket	
	<p><b>90\" Wall Mount Bracket with 2-3/8\" O.D. Tenon</b>                      NO. WM-SP-D                      Finish: Dark Bronze                      USE: The 90\" wall mount bracket with 2-3/8\" tenon attaches an MESTER floodlight to almost any surface: wall, roof, or wood pole. Provides wiring access and allows a 2-3/8\" O.D. tenon to mount a fixture with our adjustable slipfitter. Suggested 3/8\" diameter bolts for mounting. Mounting holes are spaced 3-1/4\" apart.</p>		<p><b>2-3/8\" OD Horizontal Tenon Mid-Pole Bracket</b>                      NO. SQ-SP-D                      Finish: Dark Bronze                      USE: The 2-3/8\" OD Horizontal Tenon Mid-Pole Bracket is designed to mount light fixture that is equipped with an adjustable slipfitter onto a 2-3/8\" OD horizontal tenon.</p>
Round External Mount Horizontal Tenon * To mount 2/3/4 fixtures on a existing pole			
	<p><b>Double 90\" Horizontal Tenon Adaptor</b>                      NO. R60-SP2-90-D                      Finish: Dark Bronze                      USE: The Bracket is designed to mount over 2-3/8\" (60mm) O.D. vertical tenon. Two fixtures can be mounted to the Round External Mount Horizontal Tenon and adjusted horizontally.</p>		<p><b>Triple 120\" Horizontal Tenon Adaptor</b>                      NO. R60-SP3-120-D                      Finish: Dark Bronze                      USE: The Bracket is designed to mount over 2-3/8\" (60mm) O.D. vertical tenon. Three fixtures can be mounted to the Round External Mount Horizontal Tenon and adjusted horizontally.</p>
	<p><b>Double 180\" Horizontal Tenon Adaptor</b>                      NO. R60-SP2-180-D                      Finish: Dark Bronze                      USE: The Bracket is designed to mount over 2-3/8\" (60mm) O.D. vertical tenon. Two fixtures can be mounted to the Round External Mount Horizontal Tenon and adjusted horizontally.</p>		<p><b>Quad 90\" Horizontal Tenon Adaptor</b>                      NO. R60-SP4-90-D                      Finish: Dark Bronze                      USE: The Bracket is designed to mount over 2-3/8\" (60mm) O.D. vertical tenon. Four fixtures can be mounted to the Round External Mount Horizontal Tenon and adjusted horizontally.</p>
	<p><b>Triple 90\" Horizontal Tenon Adaptor</b>                      NO. R60-SP3-90-D                      Finish: Dark Bronze                      USE: The Bracket is designed to mount over 2-3/8\" (60mm) O.D. vertical tenon. Three fixtures can be mounted to the Round External Mount Horizontal Tenon and adjusted horizontally.</p>		



DLC Model NO.

SYSTEM WATTS	VOLTAGE	CGT	DIST TYPE	DLC NO	DLC Classification
40W	120-277V	4000K	3	MAL0440W27V40K[D,B,W,SG][Blank,P0,P3,P4][Blank,M][SQ,SP,WM]T3	Premium
		5000K	3	MAL0440W27V50K[D,B,W,SG][Blank,P0,P3,P4][Blank,M][SQ,SP,WM]T3	Premium
		4000K	4	MAL0440W27V40K[D,B,W,SG][Blank,P0][Blank,M][SQ,SP,WM]T4	Premium
		5000K	4	MAL0440W27V50K[D,B,W,SG][Blank,P0][Blank,M][SQ,SP,WM]T4	Premium
		4000K	5	MAL0440W27V40K[D,B,W,SG][Blank,P0][Blank,M][SQ,SP,WM]T5	Premium
70W	120-277V	5000K	6	MAL0440W27V50K[D,B,W,SG][Blank,P0][Blank,M][SQ,SP,WM]T5	Premium
		4000K	3	MAL0470W27V40K[D,B,W,SG][Blank,P0,P3,P4][Blank,M][SQ,SP,WM]T3	Premium
		5000K	3	MAL0470W27V50K[D,B,W,SG][Blank,P0,P3,P4][Blank,M][SQ,SP,WM]T3	Premium
		4000K	4	MAL0470W27V40K[D,B,W,SG][Blank,P0][Blank,M][SQ,SP,WM]T4	Premium
		5000K	4	MAL0470W27V50K[D,B,W,SG][Blank,P0][Blank,M][SQ,SP,WM]T4	Premium
100W	120-277V	4000K	4	MAL0470W27V40K[D,B,W,SG][Blank,P0][Blank,M][SQ,SP,WM]T5	Premium
		5000K	5	MAL0470W27V50K[D,B,W,SG][Blank,P0][Blank,M][SQ,SP,WM]T5	Premium
		4000K	3	MAL04100W27V40K[D,B,W,SG][Blank,P0,P3,P4][Blank,M][SQ,SP,WM]T3	Premium
		5000K	3	MAL04100W27V50K[D,B,W,SG][Blank,P0,P3,P4][Blank,M][SQ,SP,WM]T3	Premium
		4000K	4	MAL04100W27V40K[D,B,W,SG][Blank,P0][Blank,M][SQ,SP,WM]T4	Premium
150W	120-277V	5000K	4	MAL04100W27V50K[D,B,W,SG][Blank,P0][Blank,M][SQ,SP,WM]T4	Premium
		4000K	4	MAL04100W27V40K[D,B,W,SG][Blank,P0][Blank,M][SQ,SP,WM]T4	Premium
		4000K	5	MAL04100W27V40K[D,B,W,SG][Blank,P0,P3,P4][Blank,M][SQ,SP,WM]T5	Premium
		5000K	5	MAL04100W27V50K[D,B,W,SG][Blank,P0,P3,P4][Blank,M][SQ,SP,WM]T5	Premium
		4000K	3	MAL04150W27V40K[D,B,W,SG][Blank,P0,P3,P4][Blank,M][SQ,SP,WM]T3	Premium
	347-480V	5000K	3	MAL04150W27V50K[D,B,W,SG][Blank,P0,P3,P4][Blank,M][SQ,SP,WM]T3	Premium
		5000K	3	MAL04150W48V50K[D,B,W,SG][Blank,P0,P3,P4][Blank,M][SQ,SP,WM]T3	Premium
		4000K	4	MAL04150W48V40K[D,B,W,SG][Blank,P0,P3,P4][Blank,M][SQ,SP,WM]T4	Premium
		5000K	4	MAL04150W48V50K[D,B,W,SG][Blank,P0,P3,P4][Blank,M][SQ,SP,WM]T4	Premium
		5000K	5	MAL04150W48V40K[D,B,W,SG][Blank,P0,P3,P4][Blank,M][SQ,SP,WM]T5	Premium
200W	120-277V	5000K	5	MAL04150W48V50K[D,B,W,SG][Blank,P0,P3,P4][Blank,M][SQ,SP,WM]T5	Premium
		5000K	5	MAL04200W27V40K[D,B,W,SG][Blank,P0,P3,P4][Blank,M][SQ,SP,WM]T5	Premium
		4000K	3	MAL04200W27V50K[D,B,W,SG][Blank,P0,P3,P4][Blank,M][SQ,SP,WM]T3	Premium
		4000K	4	MAL04200W27V40K[D,B,W,SG][Blank,P0,P3,P4][Blank,M][SQ,SP,WM]T4	Premium
		5000K	4	MAL04200W27V50K[D,B,W,SG][Blank,P0,P3,P4][Blank,M][SQ,SP,WM]T4	Premium
	347-480V	4000K	5	MAL04200W27V40K[D,B,W,SG][Blank,P0,P3,P4][Blank,M][SQ,SP,WM]T5	Standard
		5000K	5	MAL04200W27V50K[D,B,W,SG][Blank,P0,P3,P4][Blank,M][SQ,SP,WM]T5	Standard
		4000K	3	MAL04200W48V40K[D,B,W,SG][Blank,P0,P3,P4][Blank,M][SQ,SP,WM]T3	Premium
		5000K	3	MAL04200W48V50K[D,B,W,SG][Blank,P0,P3,P4][Blank,M][SQ,SP,WM]T3	Premium
		4000K	4	MAL04200W48V40K[D,B,W,SG][Blank,P0,P3,P4][Blank,M][SQ,SP,WM]T4	Premium
250W	120-277V	5000K	4	MAL04200W48V50K[D,B,W,SG][Blank,P0,P3,P4][Blank,M][SQ,SP,WM]T4	Premium
		5000K	5	MAL04200W48V40K[D,B,W,SG][Blank,P0,P3,P4][Blank,M][SQ,SP,WM]T5	Standard
		5000K	5	MAL04250W27V40K[D,B,W,SG][Blank,P0,P3,P4][Blank,M][SQ,SP,WM]T5	Standard
		4000K	3	MAL04250W27V50K[D,B,W,SG][Blank,P0,P3,P4][Blank,M][SQ,SP,WM]T3	Premium
		4000K	4	MAL04250W27V40K[D,B,W,SG][Blank,P0,P3,P4][Blank,M][SQ,SP,WM]T4	Premium
	347-480V	4000K	5	MAL04250W27V50K[D,B,W,SG][Blank,P0,P3,P4][Blank,M][SQ,SP,WM]T5	Premium
		4000K	5	MAL04250W48V40K[D,B,W,SG][Blank,P0,P3,P4][Blank,M][SQ,SP,WM]T5	Premium
		4000K	4	MAL04250W48V50K[D,B,W,SG][Blank,P0,P3,P4][Blank,M][SQ,SP,WM]T4	Premium
		5000K	4	MAL04250W48V40K[D,B,W,SG][Blank,P0,P3,P4][Blank,M][SQ,SP,WM]T4	Premium
		5000K	5	MAL04250W48V50K[D,B,W,SG][Blank,P0,P3,P4][Blank,M][SQ,SP,WM]T5	Premium
300W	120-277V	4000K	3	MAL04250W48V50K[D,B,W,SG][Blank,P0,P3,P4][Blank,M][SQ,SP,WM]T5	Premium
		4000K	3	MAL04300W27V40K[D,B,W,SG][Blank,P0,P3,P4][Blank,M][SQ,SP,WM]T3	Premium
		4000K	4	MAL04300W27V50K[D,B,W,SG][Blank,P0,P3,P4][Blank,M][SQ,SP,WM]T4	Premium
		5000K	4	MAL04300W27V40K[D,B,W,SG][Blank,P0,P3,P4][Blank,M][SQ,SP,WM]T4	Premium
		5000K	5	MAL04300W27V50K[D,B,W,SG][Blank,P0,P3,P4][Blank,M][SQ,SP,WM]T5	Premium
	347-480V	5000K	5	MAL04300W27V40K[D,B,W,SG][Blank,P0,P3,P4][Blank,M][SQ,SP,WM]T5	Premium
		4000K	3	MAL04300W27V50K[D,B,W,SG][Blank,P0,P3,P4][Blank,M][SQ,SP,WM]T3	Premium
		5000K	3	MAL04300W48V40K[D,B,W,SG][Blank,P0,P3,P4][Blank,M][SQ,SP,WM]T3	Premium
		4000K	4	MAL04300W48V50K[D,B,W,SG][Blank,P0,P3,P4][Blank,M][SQ,SP,WM]T4	Premium
		5000K	4	MAL04300W48V40K[D,B,W,SG][Blank,P0,P3,P4][Blank,M][SQ,SP,WM]T4	Premium



**MESTER LED LIMITED**  
 3rd F, Section B, Building A, Sunshine Industrial Park,  
 Hezhou, Xixiang, Bao'an District, Shenzhen China.  
 P: +86 755 28173385 Email: sales@szmester.com

196 196 196 196 196 196 196 196 196 196  
 196 196 196 196 196 196 196 196 196 196

**PART G**  
**AERIAL PHOTOS**



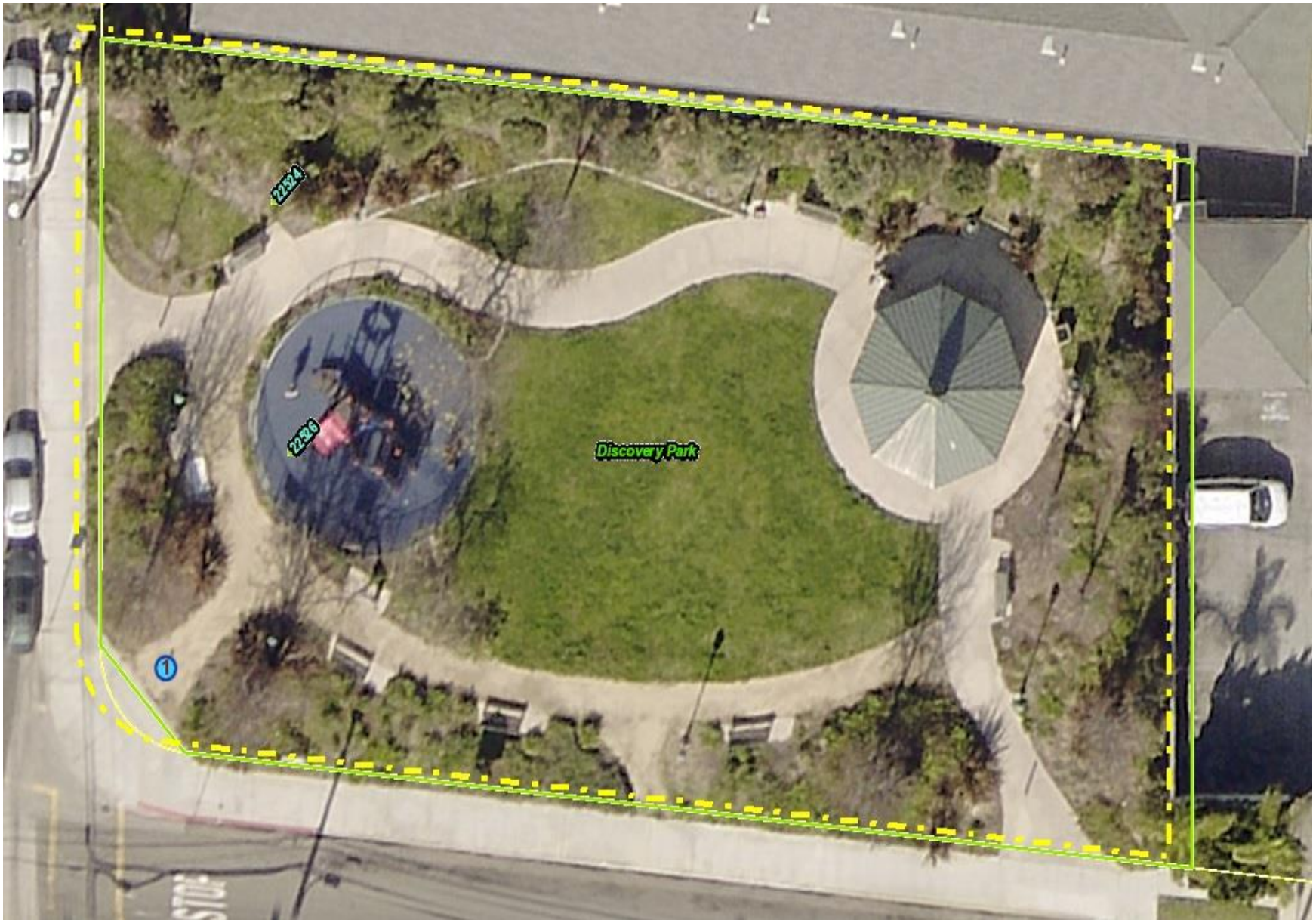

***DISCOVERY PARK - 22526 OCEAN AVE, TORRANCE, CA 90505***





***EL NIDO PARK - 18301 KINGSDALE AVE, REDONDO BEACH, CA 90278***



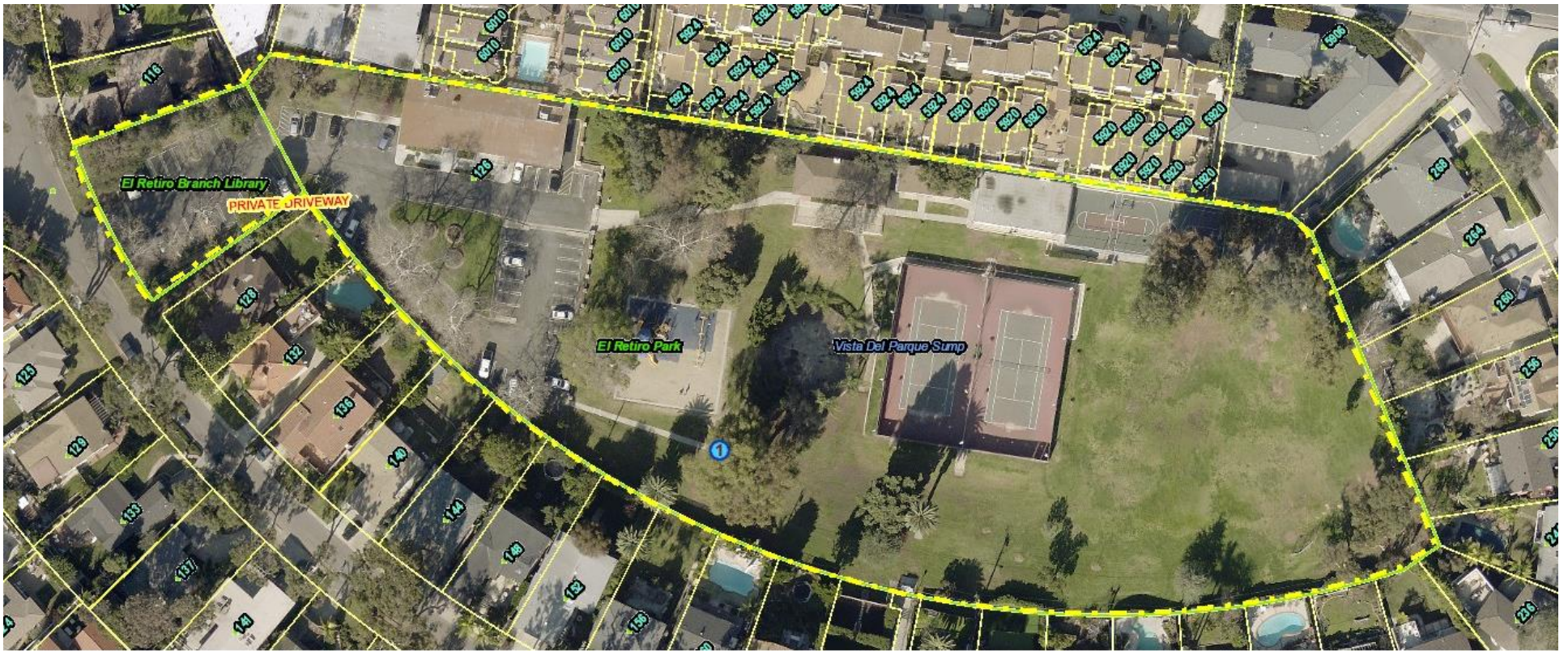

***EL RETIRO PARK – 126 VISTA DEL PARQUE, REDONDO BEACH, CA 90277***



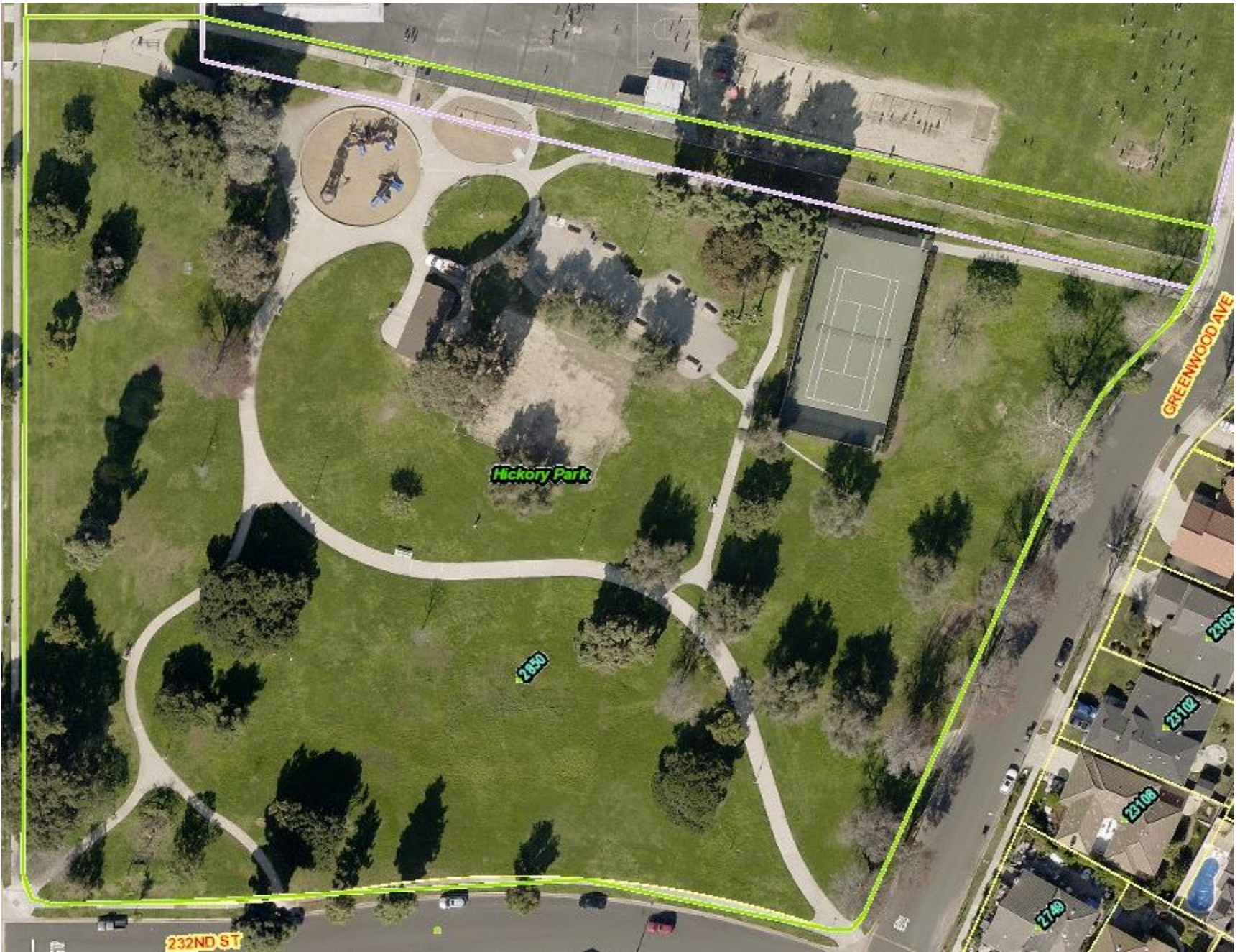



***HICKORY PARK - 2850 W. 232ND ST, TORRANCE, CA 90505***

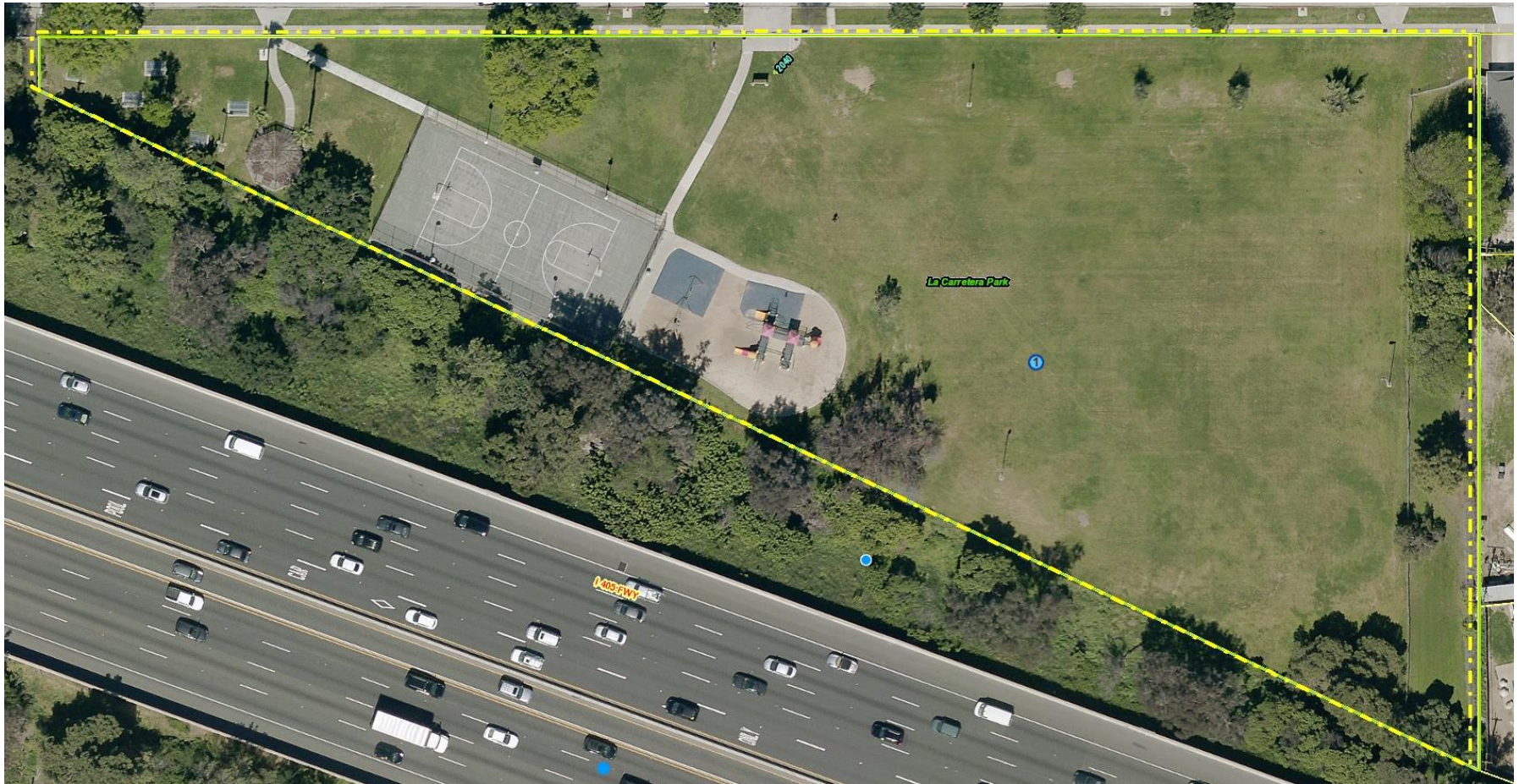

***LA CARRETARA PARK - 2040 186TH ST, TORRANCE, CA 90504***







***OSAGE PARK - 17002 OSAGE AVE, TORRANCE, CA 90504***



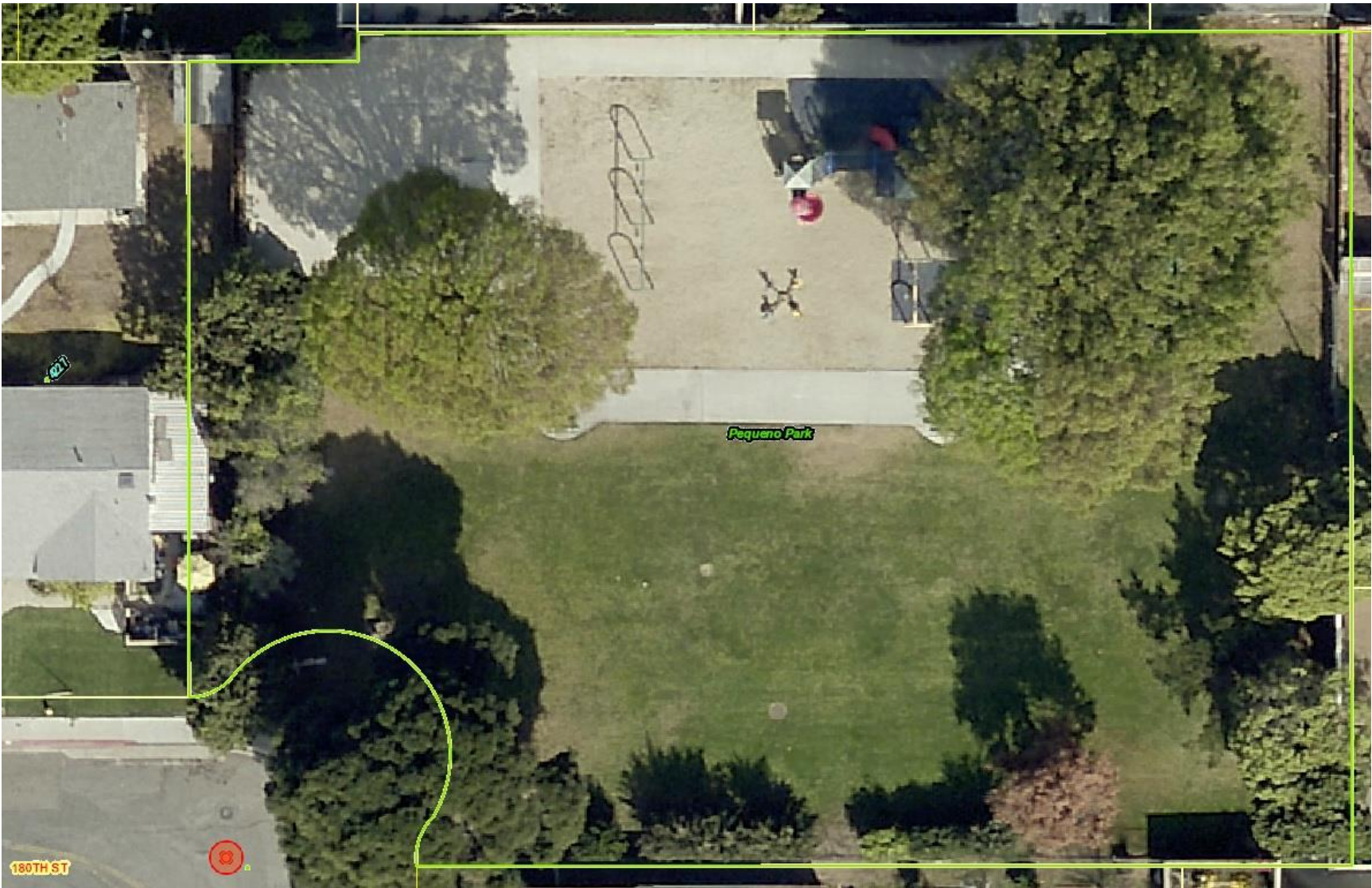

***PEQUENO PARK - 180TH ST & REGINA AVE, TORRANCE, CA 90504***





***SUNNYGLEN PARK - 5525 DEL AMO BLVD, TORRANCE, CA 90503***





***VICTOR PARK - 4727 EMERALD ST, TORRANCE, CA 90503***



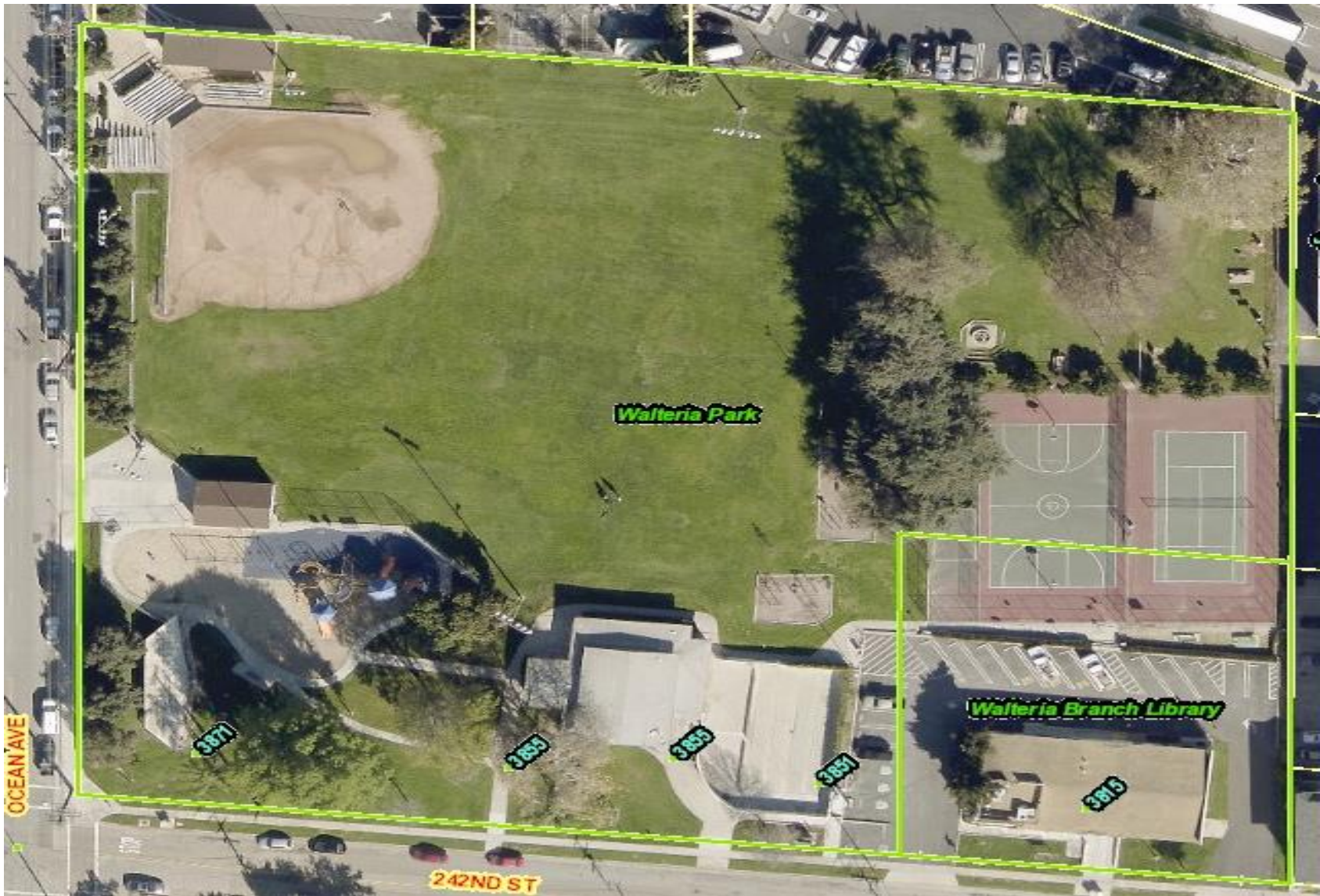

***WALTERIA PARK - 3855 W. 242ND ST, TORRANCE, CA 90505***





***PARADISE PARK - 5006 LEE ST, TORRANCE, CA 90503***



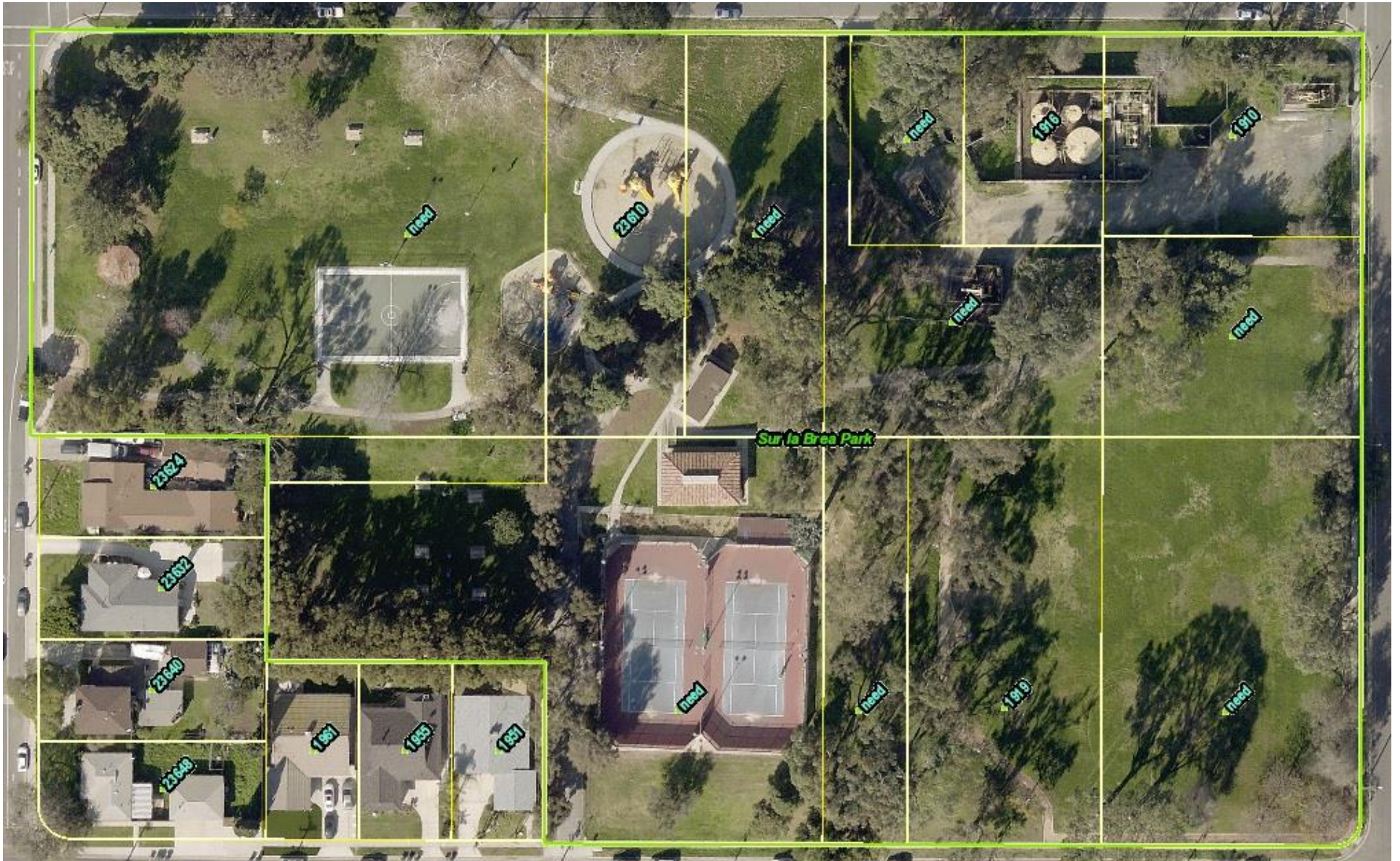

***SUR LA BREA PARK - 1951 W. 237TH ST, TORRANCE, CA 90501***





***SEA-AIRE PARK - 22730 LUPINE DR, TORRANCE, CA 90505***





***DELTHORNE PARK - 3401 SPENCER ST, TORRANCE, CA 90501***



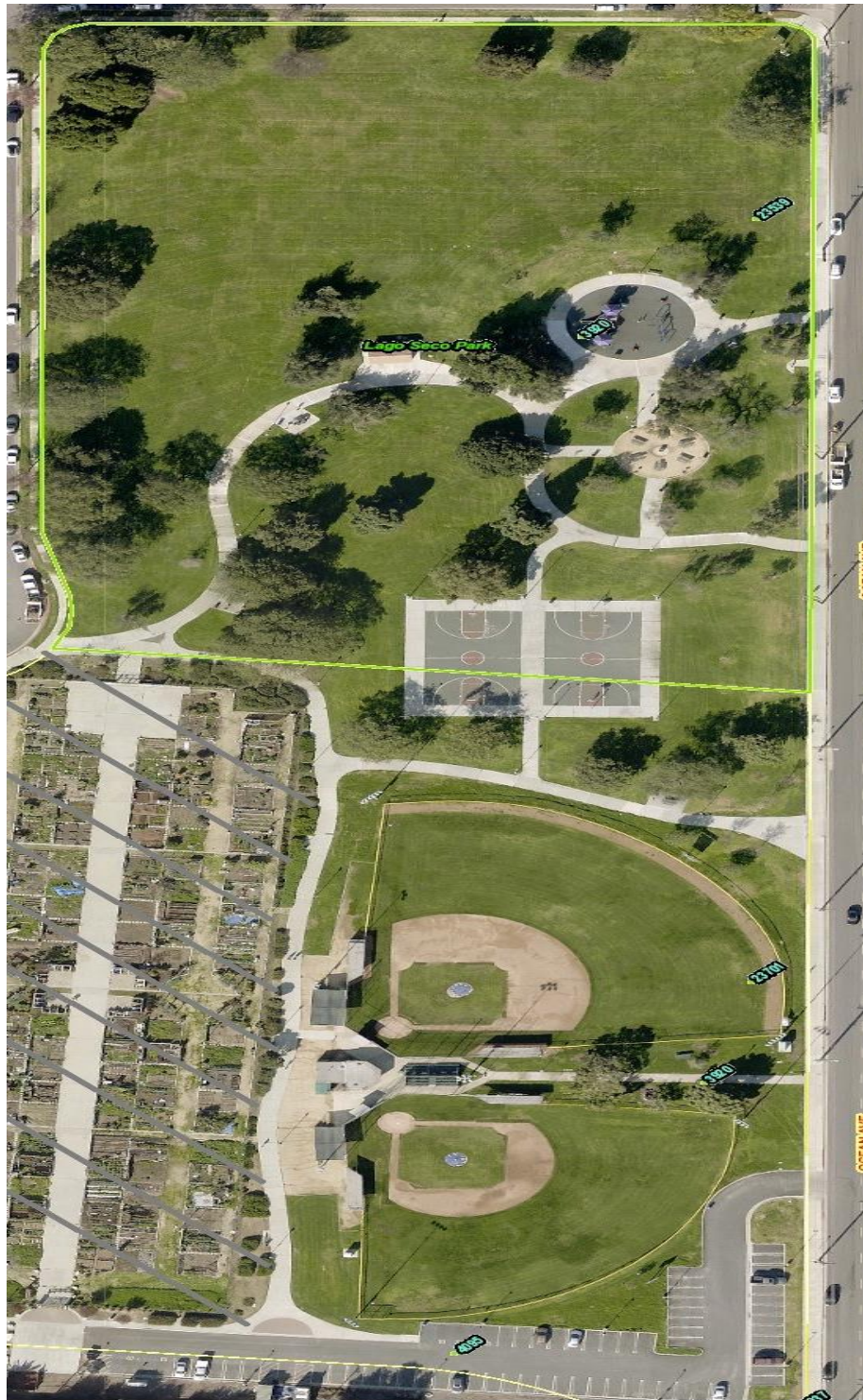

***LAGO SECO PARK - 3920 W. 235TH ST, TORRANCE, CA 90505***



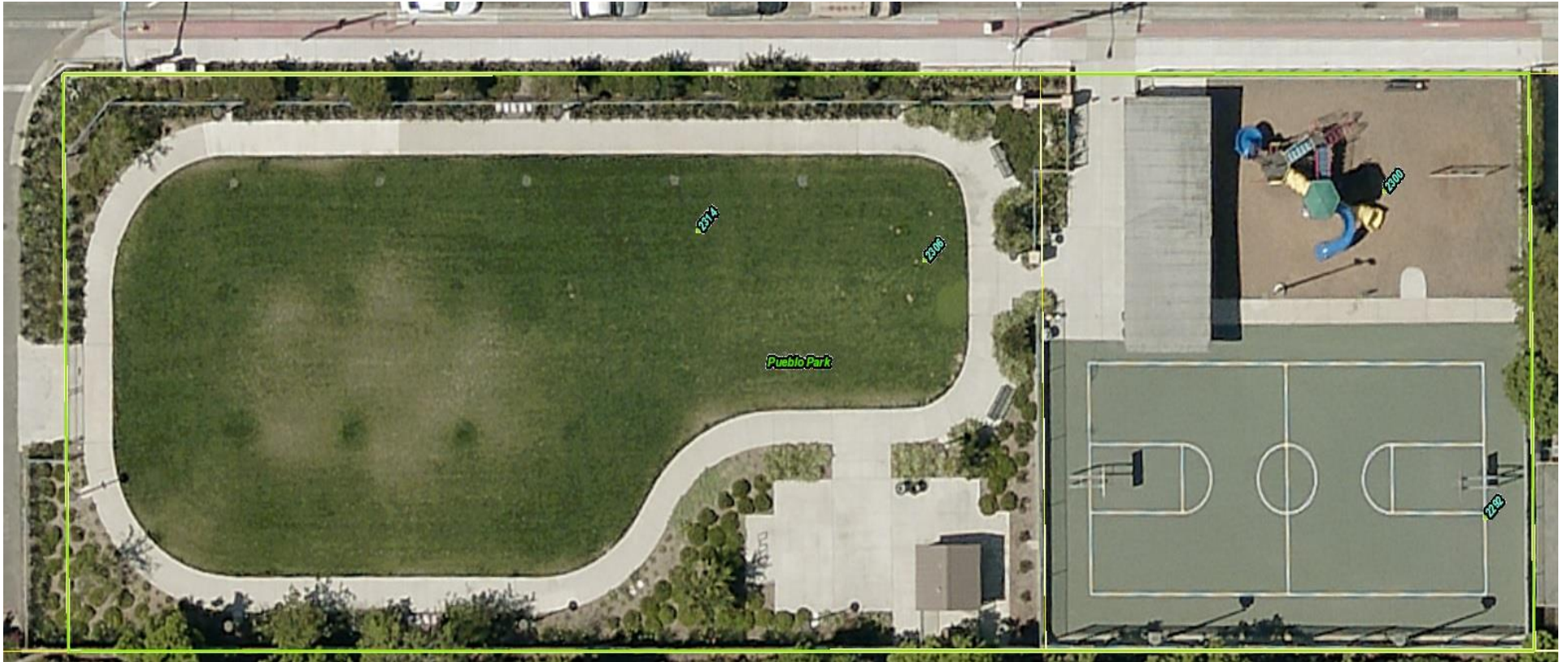

***PUEBLO PARK - 2252 DEL AMO BLVD., TORRANCE, CA 90501***

**PART H**  
**PREVAILING WAGES**



(018.167-010) T	02/22/2020	09/30/2020**	52.060	11.600	11.150	F	4.770	1.150	0.150	8.0	80.880	P	106.910	P	106.910	132.940
INSTRUMENTMAN																
(018.167-034) T	02/22/2020	09/30/2020**	49.260	11.600	11.150	F	4.600	1.150	0.150	8.0	77.910	P	102.540	P	102.540	127.170
CHAINMAN/ROOMMAN																
(069.567-010) T	02/22/2020	09/30/2020**	48.680	11.600	11.150	F	4.550	1.150	0.150	8.0	77.280	P	101.620	P	101.620	125.960
# GLAZIER																
# MARBLE FINISHER	02/22/2020	05/31/2020*	45.450	7.750	12.950	W	-	0.770	0.880	8.0	67.800	X	89.530	X	89.530	111.250
# PAINTER:	08/22/2019	05/31/2020*	33.430	9.250	3.950	Y	-	0.910	0.370	8.0	47.910	Z	64.630	AA	64.630	AB 81.340
PAINTER, LEAD ABATEMENT																
AC	02/22/2020	06/30/2020**	32.120	8.900	4.040	L	2.550	0.600	1.010	8.0	49.220	AD	65.280	AD	65.280	AD 65.280
REPAINT PAINTER, LEAD																
ABATEMENT AC	02/22/2020	06/30/2020**	28.590	8.900	4.040	L	2.430	0.600	1.010	8.0	45.570	AE	59.870	AE	59.870	AE 59.870
PAINTER, LEAD ABATEMENT																
AF	02/22/2020	06/30/2020**	27.680	8.900	4.040	L	2.410	0.600	1.010	8.0	44.640	AD	58.480	AD	58.480	AD 58.480
REPAINT PAINTER, LEAD																
ABATEMENT AF	02/22/2020	06/30/2020**	25.400	8.900	4.040	L	2.330	0.600	1.010	8.0	42.280	AE	54.980	AE	54.980	AE 54.980
INDUSTRIAL PAINTER AC																
INDUSTRIAL REPAINT	02/22/2020	06/30/2020**	34.020	8.900	4.040	L	2.850	0.700	1.010	8.0	51.520	AD	68.530	AD	68.530	AD 68.530
PAINTER AC																
GRAFFITI REMOVAL WORKER	02/22/2020	06/30/2020**	30.340	8.900	4.040	L	2.710	0.700	1.010	8.0	47.700	AE	62.870	AE	62.870	AE 62.870
JOURNEYMAN (APPLIES ONLY																
TO PAINT-OVER METHOD) AH	02/22/2020	01/31/2021*	23.000	7.900	0.640	-	-	0.750	-	8.0	32.290	J	43.790	J	43.790	55.290
GRAFFITI REMOVAL WORKER																
1 (APPLIES ONLY TO																
PAINT-OVER METHOD) AH	02/22/2020	01/31/2021*	16.000	7.900	0.640	-	-	0.750	-	8.0	25.290	J	33.290	J	33.290	41.290
GRAFFITI REMOVAL WORKER																
2 (APPLIES ONLY TO																
PAINT-OVER METHOD) AI	02/22/2020	01/31/2021*	16.870	7.900	0.640	-	-	0.750	-	8.0	26.160	J	34.600	J	34.600	43.030
# PLASTERER																
# PLASTER TENDER AM	08/22/2019	08/04/2020**	37.860	9.380	5.840	AJ	5.870	0.810	1.040	AK	60.800	AD	79.730	AL	79.730	98.660
PLASTER CLEAN-UP LABORER	08/22/2019	08/04/2020**	37.370	7.470	8.300	AN	5.180	1.020	0.960	8.0	60.300	AO	78.990	AP	78.990	97.670
# PLUMBER:	08/22/2019	08/04/2020**	34.820	7.470	8.300	AN	5.180	1.020	0.960	8.0	57.750	AO	75.160	AP	75.160	92.570
PLUMBER, INDUSTRIAL AND																
GENERAL PIPEFITTER	02/22/2020	08/31/2020**	51.380	9.160	AR	12.250	AS	2.250	AT	1.270	8.0	76.310	D	101.080	D	124.220
SEWER AND STORM DRAIN																
PIPELAYER	02/22/2020	08/31/2020**	38.490	9.050	AR	9.400	AS	1.980	AT	1.270	8.0	60.190	AU	78.510	AU	96.220
SEWER AND STORM DRAIN																
PIPE TRADESMAN AV	02/22/2020	08/31/2020**	19.040	8.800	0.380	-	-	1.110	AT	1.120	8.0	30.450	AU	39.040	AU	47.640
FITTER																
LANDSCAPE/IRRIGATION	08/22/2019	08/31/2020**	34.400	9.160	AR	12.250	AS	1.640	AT	1.070	AU	8.0	58.520	AU	75.720	91.570
LANDSCAPE/IRRIGATION																
TRADESMAN AX	08/22/2019	08/31/2020**	14.940	3.000	AR	1.130	-	0.100	AT	0.870	AU	8.0	20.040	AU	27.510	34.980
REFRIGERATION SERVICE																
HVACR	02/22/2020	08/30/2020**	48.850	10.620	AY	9.840	R	2.000	AZ	0.600	8.0	71.910	BA	96.330	BA	119.390
REFRIGERATION SERVICE																
TRADESMAN HVACR	02/22/2020	08/30/2020*	14.100	10.620	2.010	R	-	1.050	AZ	0.480	8.0	28.260	BA	35.310	BA	41.810



FIRE SPRINKLER FITTER (PROTECTION AND CONTROL SYSTEMS, OVERHEAD AND UNDERGROUND) BB	02/22/2020	03/31/2020**	39.830	10.230 BC	13.560	-	0.520	0.250	8.0 64.390	84.310	84.310	104.220
FIRE SPRINKLER FITTER (PROTECTION AND CONTROL SYSTEMS, OVERHEAD AND UNDERGROUND) BD	02/22/2020	08/31/2020*	46.510	10.230	16.800	R	1.600	0.300	8.0 75.440	98.690	98.690	121.950
# ROOFER	08/22/2019	07/31/2020*	39.520	8.560	BH	8.370	BI	0.510	8.0 57.590	75.470	75.470	93.360
# PITCH WORK	08/22/2019	07/31/2020*	41.270	8.560	BH	8.370	BI	0.510	8.0 59.340	78.100	78.100	96.860
# PREPARER	08/22/2019	07/31/2020*	40.520	8.560	BH	8.370	BI	0.510	8.0 58.590	76.970	76.970	95.360
# SHEET METAL WORKER BK	08/22/2019	06/30/2020*	45.780	10.870	BL	17.290	-	0.820	8.0 75.410	98.300	98.300	121.190
# SHEET METAL WORKER BN	02/22/2020	06/30/2020**	35.380	10.870	BO	15.470	-	1.670	8.0 63.740	81.430	81.430	99.120
# TERRAZZO FINISHER	02/22/2020	08/31/2020**	32.410	9.250	-	3.910	R	0.660	0.260	8.0 46.490	62.690	62.690
# TERRAZZO WORKER	02/22/2020	08/31/2020**	40.100	9.250	-	4.090	R	0.980	0.260	8.0 54.680	74.730	74.730
# TILE FINISHER	08/22/2019	05/31/2020*	28.230	9.250	-	2.560	-	0.840	0.310	8.0 41.190	55.310	55.310
# TILE LAYER	08/22/2019	05/31/2020*	40.070	9.250	-	8.090	-	1.020	8.0 58.800	78.830	78.830	98.870

GENERAL PREVAILING WAGE DETERMINATION MADE BY THE DIRECTOR OF INDUSTRIAL RELATIONS  
PURSUANT TO CALIFORNIA LABOR CODE PART 7, CHAPTER 1, ARTICLE 2, SECTIONS 1770, 1773 AND 1773.1

\* EFFECTIVE UNTIL SUPERSEDED BY A NEW DETERMINATION ISSUED BY THE DIRECTOR OF INDUSTRIAL RELATIONS. CONTACT THE OFFICE OF THE DIRECTOR - RESEARCH UNIT AT (415) 703-4774 FOR THE NEW RATES AFTER TEN DAYS AFTER THE EXPIRATION DATE IF NO SUBSEQUENT DETERMINATION IS ISSUED.

\*\* THE RATE TO BE PAID FOR WORK PERFORMED AFTER THIS DATE HAS BEEN DETERMINED. IF WORK WILL EXTEND PAST THIS DATE, THE NEW RATE MUST BE PAID AND SHOULD BE INCORPORATED IN CONTRACTS ENTERED INTO NOW. CONTACT THE OFFICE OF THE DIRECTOR - RESEARCH UNIT FOR SPECIFIC RATES AT (415) 703-4774.

# INDICATES AN APPRENTICEABLE CRAFT. THE CURRENT APPRENTICE WAGE RATES ARE AVAILABLE ON THE INTERNET @

HTTP://WWW.DIR.CA.GOV/OPRL/PWAPPWAGE/PWAPPWAGESTART.ASP.

& THE BASIC HOURLY RATE AND EMPLOYER PAYMENTS ARE NOT TAKEN FROM A COLLECTIVE BARGAINING AGREEMENT FOR THIS CRAFT OR CLASSIFICATION.

A INCLUDES AMOUNT WITHHELD FOR DUES CHECK OFF AND CONTRACT COMPLIANCE.

B INCLUDES AN AMOUNT FOR JMI TRAINING FUND.

C SATURDAYS IN THE SAME WORK WEEK MAY BE WORKED AT STRAIGHT-TIME IF JOB IS SHUT DOWN DURING THE NORMAL WORKWEEK DUE TO INCLEMENT WEATHER, OR REASONS BEYOND THE CONTROL OF THE EMPLOYER.

D RATE APPLIES TO THE FIRST 2 DAILY OVERTIME HOURS AND THE FIRST 10 HOURS ON SATURDAY; ALL OTHER TIME IS PAID AT THE SUNDAY AND HOLIDAY OVERTIME HOURLY RATE.

E THE RATIO OF BRICK TENDERS TO BRICKLAYERS SHALL BE AS FOLLOWS: ONE (1) BRICK TENDER TO NO MORE THAN THREE (3) BRICKLAYERS DURING THE INSTALLATION OF BLOCK ON A TYPICAL MASONRY PROJECT.

F INCLUDES AN AMOUNT PER HOUR WORKED FOR SUPPLEMENTAL DUES.

G INCLUDES AMOUNT WITHHELD FOR DUES CHECK OFF.

H RATE APPLIES TO THE FIRST 12 HOURS WORKED ON SATURDAY, ALL OTHER TIME IS PAID AT DOUBLE TIME. SATURDAY MAY BE WORKED AT THE STRAIGHT-TIME HOURLY RATE FOR THE FIRST 8 HOURS IF INCLEMENT WEATHER FORCES A SYNTHETIC/ARTIFICIAL TURF PROJECT TO SHUT DOWN DURING THE REGULAR WORK WEEK (MONDAY THROUGH FRIDAY).

I A MATERIAL HANDLER MAY BE UTILIZED IN RATIO OF ONE (1) MATERIAL HANDLER WITH ANY FIVE (5) JOURNEYMEN ON ANY GIVEN PROJECT.

- J RATE APPLIES TO THE FIRST 12 HOURS ON SATURDAY, ALL OTHER TIME IS PAID AT DOUBLE TIME.
- K RATE ONLY APPLIES TO WORK PERFORMED IN ANTELOPE VALLEY WHICH IS HIGHWAY 5, SOUTH ON U.S. 5 TO HIGHWAY N2; EAST ON HIGHWAY N2 TO PALMDALE BLVD TO HIGHWAY 14; SOUTH TO HIGHWAY 18; EAST TO HIGHWAY 395.
- L INCLUDES AMOUNT WITHHELD FOR WORKING DUES.
- M RATE APPLIES TO FIRST 8 HOURS ONLY. DOUBLE TIME THEREAFTER. SATURDAYS IN THE SAME WORK WEEK MAY BE WORKED AT STRAIGHT-TIME IF JOB IS SHUT DOWN DURING THE NORMAL WORK WEEK DUE TO INCLEMENT WEATHER.
- N IN ADDITION, AN AMOUNT EQUAL TO 3% OF THE BASIC HOURLY RATE IS ADDED TO THE TOTAL HOURLY RATE AND OVERTIME HOURLY RATES FOR THE NATIONAL EMPLOYEES BENEFIT BOARD.
- O INCLUDES AN AMOUNT FOR THE NATIONAL LABOR-MANAGEMENT COOPERATION FUND AND THE ADMINISTRATIVE MAINTENANCE FUND.
- P RATE APPLIES TO THE FIRST 4 DAILY OVERTIME HOURS AND THE FIRST 12 HOURS WORKED ON SATURDAY; ALL OTHER TIME IS PAID AT THE SUNDAY AND HOLIDAY OVERTIME HOURLY RATE.
- Q IN ADDITION, AN AMOUNT EQUAL TO 3% OF THE BASIC HOURLY RATE IS ADDED TO THE TOTAL HOURLY RATE AND OVERTIME HOURLY RATES FOR THE NATIONAL EMPLOYEES BENEFIT BOARD. PURSUANT TO LABOR CODE SECTIONS 1773.1 AND 1773.8, THE AMOUNT PAID FOR THIS EMPLOYER PAYMENT MAY VARY RESULTING IN A LOWER TAXABLE BASIC HOURLY WAGE RATE, BUT THE TOTAL HOURLY RATES FOR STRAIGHT TIME AND OVERTIME MAY NOT BE LESS THAN THE GENERAL PREVAILING RATE OF PER DIEM WAGES.
- R INCLUDED IN STRAIGHT-TIME HOURLY RATE.
- S THE MAXIMUM ALLOWABLE RATIO IS ONE TRANSPORTATION SYSTEMS TECHNICIAN TO ONE JOURNEYMAN ON EACH JOB.
- T DICTIONARY OF OCCUPATIONAL TITLES, FOURTH EDITION, 1977, U.S. DEPARTMENT OF LABOR.
- U INCLUDES AMOUNT WITHHELD FOR DUES CHECKOFF, WHICH IS FACTORED IN THE OVERTIME RATES. INCLUDES \$2.00 OF VACATION THAT IS NOT FACTORED IN THE OVERTIME RATES.
- V INCLUDES AN AMOUNT PER HOUR WORKED OR PAID TO DISABILITY FUND.
- W INCLUDED IN STRAIGHT-TIME HOURLY RATE WHICH IS NOT FACTORED IN THE OVERTIME RATES.
- X RATE APPLIES TO THE FIRST 2 OVERTIME HOURS MONDAY THROUGH FRIDAY AND THE FIRST 8 HOURS WORKED ON SATURDAY. ALL OTHER TIME IS PAID AT THE SUNDAY AND HOLIDAY OVERTIME RATE.
- Y INCLUDES AMOUNT WITHHELD FOR ADMINISTRATIVE DUES.
- Z RATE APPLIES TO FIRST TWO DAILY OVERTIME HOURS WORKED; ALL OTHER OVERTIME IS PAID AT THE HOLIDAY OVERTIME HOURLY RATE.
- AA RATE APPLIES TO THE FIRST 8 HOURS WORKED ON A SIXTH OR SEVENTH CONSECUTIVE DAY DURING ANY ONE CALENDAR WEEK UP TO 50 HOURS IN ANY ONE CALENDAR WEEK. ALL HOURS IN EXCESS OF 10 HOURS DAILY OR 50 HOURS WEEKLY ARE PAID AT THE HOLIDAY RATE. SATURDAYS IN THE SAME WORK WEEK MAY BE WORKED AT STRAIGHT-TIME IF JOB IS SHUT DOWN DURING THE NORMAL WORKWEEK DUE TO INCLEMENT WEATHER.
- AB RATE APPLIES TO WORK ON HOLIDAYS ONLY; SUNDAYS ARE PAID AT THE SATURDAY OVERTIME HOURLY RATE.
- AC AN ADDITIONAL \$0.25 PER HOUR WILL BE ADDED TO THE BASIC HOURLY RATE WHEN PERFORMING PAPERHANGING WORK.
- AD DOUBLE TIME SHALL BE PAID FOR ALL HOURS WORKED OVER 12 HOURS IN ANY ONE DAY.
- AE ON REPAINT WAGE WORK ANY 8 HOURS IN A 24 HOUR PERIOD MONDAY THROUGH SUNDAY SHALL BE THE WORK DAY AND ANY 40 HOURS IN A WEEK SHALL BE THE WORK WEEK, PROVIDED THAT THE 40 HOURS IS WORKED IN 5 CONSECUTIVE DAYS (LEGAL HOLIDAYS WILL NOT BE COUNTED IN THE 5 CONSECUTIVE DAYS). FOR ALL WORK UNDER THIS CRAFT/CLASSIFICATION DOUBLE TIME SHALL BE PAID FOR ALL HOURS WORKED OVER 12 HOURS IN ANY ONE DAY.
- AF RATE ONLY APPLIES TO WORK PERFORMED IN ANTELOPE VALLEY, WHICH IS HIGHWAY 5, SOUTH ON U.S. 5 TO HIGHWAY N2; EAST ON HIGHWAY N2 TO PALMDALE BLVD TO HIGHWAY 14; SOUTH TO HIGHWAY 18; EAST TO HIGHWAY 395. AN ADDITIONAL \$0.25 IS ADDED TO THE BASIC HOURLY RATE WHEN PERFORMING PAPERHANGING WORK.
- AG RATE APPLIES AFTER 36 MONTHS OF EXPERIENCE
- AH RATE APPLIES TO FIRST 12 MONTHS OF EXPERIENCE
- AI RATE APPLIES AFTER 12 MONTHS THROUGH 36 MONTHS EXPERIENCE
- AJ INCLUDES AN AMOUNT PER HOUR WORKED OR PAID FOR DUES CHECK OFF
- AK SATURDAY IN THE SAME WORKWEEK MAY BE WORKED AT THE STRAIGHT-TIME HOURLY RATE IF IT IS NOT POSSIBLE TO COMPLETE FORTY HOURS OF WORK MONDAY THROUGH FRIDAY WHEN THE JOB IS SHUT DOWN DUE TO INCLEMENT WEATHER OR SIMILAR ACT OF GOD, OR BEYOND THE CONTRACTOR'S CONTROL.
- AL RATE APPLIES TO THE FIRST 8 HOURS WORKED; ALL OTHER TIME IS PAID AT THE SUNDAY AND HOLIDAY OVERTIME HOURLY RATE.
- AM THE RATIO OF PLASTER TENDERS TO PLASTERERS SHALL BE AS FOLLOWS: THERE SHALL BE A PLASTER TENDER ON THE JOBSITE WHENEVER THERE IS A PLASTERER PERFORMING WORK ON THE JOBSITE, EXCEPT ON SMALL PATCH WORK WHERE ONLY ONE PLASTERER IS PERFORMING WORK. FOR INSIDE BROWN COATINGS THERE SHALL BE 2 PLASTERERS FOR UP TO EVERY 3 PLASTERERS. FOR INSIDE FINISH COATINGS THERE SHALL BE 1 PLASTER TENDER FOR UP TO EVERY 3 PLASTERERS. ON OUTSIDE

FINISH AND BROWN COATINGS AND FOR ALL OTHER WORK, THERE SHALL BE 1 PLASTER TENDER FOR UP TO EVERY 2 PLASTERERS, AN INCLUDES AN AMOUNT PER HOUR WORKED OR PAID FOR SUPPLEMENTAL DUES.

AO ALL WORK PERFORMED AFTER TWELVE (12) HOURS IN A DAY SHALL BE PAID AT THE SUNDAY/HOLIDAY RATE.

AP RATE APPLIES TO THE FIRST EIGHT HOURS ON SATURDAY. ALL OTHER TIME IS PAID AT THE SUNDAY AND HOLIDAY OVERTIME RATE. SATURDAY WORK MAY BE PAID AT THE STRAIGHT TIME RATE IF THE JOB IS SHUT DOWN DURING THE NORMAL WORK WEEK DUE TO INCLEMENT WEATHER.

AQ INCLUDES AN AMOUNT WITHHELD FOR ADMINISTRATIVE DUES WHICH IS NOT FACTORED INTO OVERTIME AND AN AMOUNT FOR VACATION WHICH IS FACTORED AT 1.5 TIMES FOR ALL OVERTIME.

AR INCLUDES AMOUNT FOR NATIONAL PENSION AND RETIREE'S X-MAS FUND.

AS AMOUNT INCLUDED IN BASIC HOURLY RATE AND FACTORED AT 1.5 TIMES FOR ALL OVERTIME.

AU SATURDAYS IN THE SAME WORK WEEK MAY BE WORKED AT STRAIGHT-TIME IF JOB IS SHUT DOWN DURING THE NORMAL WORKWEEK DUE TO INCLEMENT WEATHER.

AV PIPE TRADESMEN SHALL NOT BE PERMITTED ON ANY JOB WITHOUT A JOURNEYMAN.

AW INCLUDES AN AMOUNT WITHHELD FOR ADMINISTRATIVE DUES WHICH IS NOT FACTORED IN THE OVERTIME RATES.

AX TRADESMEN SHALL ONLY BE USED IF THE FIRST WORKER ON THE JOB IS A LANDSCAPE/IRRIGATION FITTER, SECOND WORKER MUST BE A LANDSCAPE/IRRIGATION FITTER OR APPRENTICE LANDSCAPE/IRRIGATION FITTER. THE 3RD AND 4TH MAY BE A TRADESMAN. THE 5TH MUST BE A LANDSCAPE/IRRIGATION FITTER AND THEREAFTER TRADESMEN WILL BE REFERRED ON A 50-50 BASIS, TO JOURNEYMAN OR APPRENTICE.

AY INCLUDES AN AMOUNT FOR 401A PLAN.

AZ INCLUDES AN AMOUNT FOR THE P.I.P.E. LABOR MANAGEMENT COOPERATION COMMITTEE TRUST FUND AND FOR PROMOTION FUND.

BA SATURDAY MAY BE PAID AT STRAIGHT TIME IF THE WORK WEEK IS TUESDAY THROUGH SATURDAY.

BB RATE APPLIES TO REMAINDER OF COUNTY.

BC INCLUDES AN AMOUNT FOR SUPPLEMENTAL PENSION FUND.

BD RATE APPLIES TO LOS ANGELES CITY LIMITS AND TWENTY-FIVE (25) MILES BEYOND CITY LIMITS OF LOS ANGELES.

BE AMOUNT IS FOR INDUSTRY PROMOTION FUND AND P.I.P.E. FUND.

BF RATE APPLIES TO THE FIRST 4 DAILY OVERTIME HOURS AND THE FIRST 10 HOURS ON SATURDAY; ALL OTHER TIME IS PAID AT THE SUNDAY AND HOLIDAY OVERTIME HOURLY RATE.

BG INCLUDE AMOUNTS FOR DUES CHECK OFF AND VACATION/HOLIDAY, WHICH ARE NOT FACTORED INTO OVERTIME.

BH INCLUDES AN AMOUNT PER HOUR WORKED FOR ANNUITY TRUST FUND.

BI INCLUDED IN BASIC HOURLY RATE. VACATION IS NOT FACTORED INTO OVERTIME.

BJ INCLUDE AMOUNTS FOR ADMINISTRATIVE FUND, COMPLIANCE FUND, INDUSTRY FUND, AND RESEARCH AND EDUCATION TRUST FUND.

BK APPLIES TO THAT PORTION OF THE COUNTY SOUTH OF A STRAIGHT LINE DRAWN BETWEEN GORMAN AND BIG PINES.

BL PURSUANT TO LABOR CODE SECTIONS 1773.1 AND 1773.8, THE AMOUNT PAID FOR THIS EMPLOYER PAYMENT MAY VARY RESULTING IN A LOWER TAXABLE BASIC HOURLY WAGE RATE, BUT THE TOTAL HOURLY RATES FOR STRAIGHT TIME AND OVERTIME MAY NOT BE LESS THAN THE GENERAL PREVAILING RATE OF PER DIEM WAGES.

BM RATE APPLIES FOR THE FIRST 4 OVERTIME HOURS MONDAY THROUGH FRIDAY AND THE FIRST 12 HOURS WORKED ON SATURDAY. ALL OTHER TIME IS PAID AT THE SUNDAY/HOLIDAY RATE. SATURDAYS IN THE SAME WORKWEEK MAY BE WORKED AT STRAIGHT-TIME IF JOB IS SHUT DOWN DURING THE NORMAL WORKWEEK DUE TO INCLEMENT WEATHER.

BN APPLIES TO THAT PORTION OF THE COUNTY NORTH OF A STRAIGHT LINE DRAWN BETWEEN GORMAN AND BIG PINES INCLUDING THE CITIES OF LANCASTER AND PALMDALE.

BO INCLUDES AMOUNTS FOR LOCAL PENSION, NATIONAL PENSION PLAN, 401(A) PLAN, RETIREE'S SUPPLEMENTAL HEALTH PLAN. PURSUANT TO LABOR CODE SECTIONS 1773.1 AND 1773.8, THE AMOUNT PAID FOR THIS EMPLOYER PAYMENT MAY VARY RESULTING IN A LOWER TAXABLE BASIC HOURLY WAGE RATE, BUT THE TOTAL HOURLY RATES FOR STRAIGHT TIME AND OVERTIME MAY NOT BE LESS THAN THE GENERAL PREVAILING RATE OF PER DIEM WAGES.

BP RATE APPLIES TO FIRST 4 DAILY OVERTIME HOURS AND THE FIRST 12 HOURS ON SATURDAY AND SUNDAY. ALL OTHER OVERTIME HOURS IS AT DOUBLE TIME RATE.

BQ RATE APPLIES TO THE FIRST 8 HOURS WORKED ON A SIXTH OR SEVENTH CONSECUTIVE DAY DURING ANY ONE CALENDAR WEEK UP TO 50 HOURS IN ANY ONE CALENDAR WEEK. ALL OTHER TIME IS PAID AT THE HOLIDAY RATE.

RECOGNIZED HOLIDAYS: HOLIDAYS UPON WHICH THE GENERAL PREVAILING HOURLY WAGE RATE FOR HOLIDAY WORK SHALL BE PAID, SHALL BE ALL HOLIDAYS IN THE COLLECTIVE BARGAINING AGREEMENT, APPLICABLE TO THE PARTICULAR CRAFT, CLASSIFICATION, OR TYPE OF WORKER EMPLOYED ON THE PROJECT, WHICH IS ON FILE WITH THE DIRECTOR OF INDUSTRIAL RELATIONS. IF THE PREVAILING RATE IS NOT BASED ON A COLLECTIVELY BARGAINED RATE, THE HOLIDAYS UPON WHICH THE PREVAILING

RATE SHALL BE PAID SHALL BE AS PROVIDED IN SECTION 6700 OF THE GOVERNMENT CODE. YOU MAY OBTAIN THE HOLIDAY PROVISIONS FOR THE CURRENT DETERMINATIONS ON THE INTERNET AT [HTTP://WWW.DIR.CA.GOV/OPRL/DpreAgeDetermination.htm](http://www.dir.ca.gov/OPRL/DpreAgeDetermination.htm). HOLIDAY PROVISIONS FOR THE CURRENT OR SUPERSEDED DETERMINATIONS MAY BE OBTAINED BY CONTACTING THE OFFICE OF THE DIRECTOR - RESEARCH UNIT AT (415) 703-4774.

TRAVEL AND/OR SUBSISTENCE: IN ACCORDANCE WITH LABOR CODE SECTIONS 1773.1 AND 1773.9, CONTRACTORS SHALL MAKE TRAVEL AND/OR SUBSISTENCE PAYMENTS TO EACH WORKER TO EXECUTE THE WORK. YOU MAY OBTAIN THE TRAVEL AND/OR SUBSISTENCE PROVISIONS FOR THE CURRENT DETERMINATIONS ON THE INTERNET AT [HTTP://WWW.DIR.CA.GOV/OPRL/DpreAgeDetermination.htm](http://www.dir.ca.gov/OPRL/DpreAgeDetermination.htm). TRAVEL AND/OR SUBSISTENCE REQUIREMENTS FOR CURRENT OR SUPERSEDED DETERMINATIONS MAY BE OBTAINED BY CONTACTING THE OFFICE OF THE DIRECTOR - RESEARCH UNIT AT (415) 703-4774.



GENERAL PREVAILING WAGE DETERMINATION MADE BY THE DIRECTOR OF INDUSTRIAL RELATIONS  
PURSUANT TO CALIFORNIA LABOR CODE PART 7, CHAPTER 1, ARTICLE 2, SECTIONS 1770, 1773 AND 1773.1  
FOR COMMERCIAL BUILDING, HIGHWAY, HEAVY CONSTRUCTION AND DREDGING PROJECTS

LOCALITY: LOS ANGELES COUNTY

DETERMINATION: LOS-2020-1

CRAFT (JOURNEY LEVEL)	ISSUE DATE	EXPIRATION DATE	BASIC HOURLY RATE	HEALTH AND WELFARE	EMPLOYER PAYMENTS			STRAIGHT-TIME			OVERTIME HOURLY RATE				
					PENSION	VACATION / HOLIDAY	TRAINING	OTHER	HOURS	TOTAL HOURLY RATE	DAILY	SATURDAY	SUNDAY AND HOLIDAY		
# CARPET, LINOLEUM, RESILIENT TILE LAYER - SECOND SHIFT	02/22/2020	12/31/2020**A	45.060	5.480	5.550	2.120	0.630	0.280	8.0	59.120	81.650	81.650	81.650	104.180	
MATERIAL HANDLER - SECOND SHIFT B	02/22/2020	12/31/2020**A	15.600	5.480	1.940	0.620	0.630	0.280	8.0	24.550	32.350	32.350	32.350	40.150	
# ELECTRICIAN:															
SOUND INSTALLER 2ND SHIFT	02/22/2020	12/27/2020**	45.360	8.560	5.120	-	0.650	0.250	8.0	61.300	84.660	84.660	84.660	108.020	
SOUND INSTALLER 3RD SHIFT	02/22/2020	12/27/2020**	50.810	8.560	5.120	-	0.650	0.250	8.0	66.910	93.080	93.080	93.080	119.250	
INSIDE WIREMAN, 2ND SHIFT	02/22/2020	07/26/2020**	56.830	12.790	14.570	-	0.760	0.500	8.0	87.150	116.420	116.420	116.420	145.690	
INSIDE WIREMAN, 3RD SHIFT	02/22/2020	07/26/2020**	63.660	12.790	14.570	-	0.760	0.500	8.0	94.190	126.970	126.970	126.970	159.760	
CABLE SPLICER-WELDER, 2ND SHIFT	02/22/2020	07/26/2020**	59.670	12.790	14.570	-	0.760	0.500	8.0	90.080	120.810	120.810	120.810	151.540	
CABLE SPLICER-WELDER, 3RD SHIFT	02/22/2020	07/26/2020**	66.840	12.790	14.570	-	0.760	0.500	8.0	97.470	131.890	131.890	131.890	166.310	
TUNNEL WIREMAN SECOND SHIFT	02/22/2020	07/26/2020**	62.520	12.790	14.570	-	0.760	0.500	8.0	93.020	125.210	125.210	125.210	157.410	
TUNNEL WIREMAN THIRD SHIFT	02/22/2020	07/26/2020**	70.040	12.790	14.570	-	0.760	0.500	8.0	100.760	136.830	136.830	136.830	172.900	
TUNNEL CABLE SPLICER SECOND SHIFT	02/22/2020	07/26/2020**	65.650	12.790	14.570	-	0.760	0.500	8.0	96.240	130.050	130.050	130.050	163.860	
TUNNEL CABLE SPLICER THIRD SHIFT	02/22/2020	07/26/2020**	73.540	12.790	14.570	-	0.760	0.500	8.0	104.370	142.240	142.240	142.240	180.110	
TRANSPORTATION SYSTEMS ELECTRICIAN (SECOND SHIFT)	02/22/2020	07/26/2020**	56.540	12.890	14.720	-	0.760	0.500	8.0	87.110	116.220	116.220	116.220	145.340	
TRANSPORTATION SYSTEMS ELECTRICIAN (THIRD SHIFT)	02/22/2020	07/26/2020**	63.330	12.890	14.720	-	0.760	0.500	8.0	94.100	126.710	126.710	126.710	159.330	
TRANSPORTATION SYSTEMS ELECTRICIAN (CABLE SPLICING, WELDING, AND META TESTING) 2ND SHIFT	02/22/2020	07/26/2020**	59.370	12.890	14.720	-	0.760	0.500	8.0	90.020	120.600	120.600	120.600	151.170	

TRANSPORTATION SYSTEMS ELECTRICIAN (CABLE SPLICING, WELDING, AND NETA TESTING) 3RD SHIFT	02/22/2020	07/26/2020**	66,500	12,890	H	14,720	I	-	0.760	0.500	8,097,370	J	131,610	K	131,610	G	165,860
TRANSPORTATION SYSTEMS TECHNICIAN (SECOND SHIFT) L	02/22/2020	07/26/2020**	42,400	12,890	H	14,720	I	-	0.760	0.500	8,072,540	J	94,380	K	94,380	G	116,210
TRANSPORTATION SYSTEMS TECHNICIAN (THIRD SHIFT) L	02/22/2020	07/26/2020**	47,500	12,890	H	14,720	I	-	0.760	0.500	8,077,790	J	102,260	K	102,260	G	126,720
# PLUMBER: PLUMBER, INDUSTRIAL AND GENERAL PIPEFITTER (2ND SHIFT)	02/22/2020	08/31/2020**	58,600	9,160	N	12,250	O	-	2.250	1.270	8,083,530	Q	111,910	Q	111,910		138,660
SEWER AND STORM DRAIN PIPELAYER (2ND SHIFT)	02/22/2020	08/31/2020**	44,080	9,050	N	9,400	O	-	1.980	1.270	8,065,780	R	86,900	R	86,900		107,400
SEWER AND STORM DRAIN PIPE TRADESMAN (2ND SHIFT) S	02/22/2020	08/31/2020**	21,900	8,800		0,380		-	1.110	1.120	8,033,310	R	43,340	R	43,340		53,360
LANDSCAPE/IRRIGATION FITTER SECOND SHIFT	08/22/2019	08/31/2020**	39,150	9,160	N	12,250	O	-	1.640	1.070	8,063,270	R	82,850	R	82,850		101,070
LANDSCAPE/IRRIGATION TRADESMAN SECOND SHIFT V	08/22/2019	08/31/2020**	17,180	3,000	N	1,130		-	0.100	0.870	8,022,280	R	30,870	R	30,870		39,460
REFRIGERATION SERVICE HVAC/R- 2ND SHIFT	02/22/2020	08/30/2020**	55,770	10,620	W	9,840	I	-	2.000	0.600	8,078,830	Y	106,710	Y	106,710	Z	133,230
FIRE SPRINKLER FITTER (PROTECTION AND CONTROL SYSTEMS, OVERHEAD AND UNDERGROUND)- 2ND SHIFT	02/22/2020	08/31/2020*	53,490	10,230		16,800	I	-	1.600	0.300	8,082,420	AC	109,170	AC	109,170		135,910
AA																	

GENERAL PREVAILING WAGE DETERMINATION MADE BY THE DIRECTOR OF INDUSTRIAL RELATIONS  
PURSUANT TO CALIFORNIA LABOR CODE PART 7, CHAPTER 1, ARTICLE 2, SECTIONS 1770, 1773 AND 1773.1

\* EFFECTIVE UNTIL SUPERSEDED BY A NEW DETERMINATION ISSUED BY THE DIRECTOR OF INDUSTRIAL RELATIONS. CONTACT THE OFFICE OF THE DIRECTOR - RESEARCH UNIT AT (415) 703-4774 FOR THE NEW RATES AFTER TEN DAYS AFTER THE EXPIRATION DATE IF NO SUBSEQUENT DETERMINATION IS ISSUED.

\*\* THE RATE TO BE PAID FOR WORK PERFORMED AFTER THIS DATE HAS BEEN DETERMINED. IF WORK WILL EXTEND PAST THIS DATE, THE NEW RATE MUST BE PAID AND SHOULD BE INCORPORATED IN CONTRACTS ENTERED INTO NOW. CONTACT THE OFFICE OF THE DIRECTOR - RESEARCH UNIT FOR SPECIFIC RATES AT (415) 703-4774.  
# INDICATES AN APPRENTICEABLE CRAFT. THE CURRENT APPRENTICE WAGE RATES ARE AVAILABLE ON THE INTERNET @ [HTTP://WWW.DIR.CA.GOV/OPRL/PWAPPAGE/PWAPPAGESTART.ASP](http://www.dir.ca.gov/OPRL/PWAPPAGE/PWAPPAGESTART.ASP).

& THE BASIC HOURLY RATE AND EMPLOYER PAYMENTS ARE NOT TAKEN FROM A COLLECTIVE BARGAINING AGREEMENT FOR THIS CRAFT OR CLASSIFICATION.

- A INCLUDES AMOUNT WITHHELD FOR DUES CHECK OFF.
- B A MATERIAL HANDLER MAY BE UTILIZED IN RATIO OF ONE (1) MATERIAL HANDLER WITH ANY FIVE (5) JOURNEYMEN ON ANY GIVEN PROJECT.
- C IN ADDITION, AN AMOUNT EQUAL TO 3% OF THE BASIC HOURLY RATE IS ADDED TO THE TOTAL HOURLY RATE AND OVERTIME HOURLY RATES FOR THE NATIONAL EMPLOYEES BENEFIT BOARD.
- D INCLUDES AN AMOUNT FOR THE NATIONAL LABOR-MANAGEMENT COOPERATION FUND AND THE ADMINISTRATIVE MAINTENANCE FUND.
- E RATE APPLIES TO THE FIRST 4 DAILY OVERTIME HOURS; ALL OTHER TIME IS PAID AT THE SUNDAY AND HOLIDAY NON-SHIFT DIFFERENTIAL OVERTIME HOURLY RATE.
- F DISREGARD THIS RATE. FOR THE FIRST 12 HOURS OF WORK PERFORMED ON SATURDAY, USE THE SATURDAY NON-SHIFT DIFFERENTIAL RATE FOR THIS CLASSIFICATION AS PUBLISHED IN THE DIRECTOR'S GENERAL PREVAILING WAGE DETERMINATIONS.
- G DISREGARD THIS RATE. USE THE SUNDAY AND HOLIDAY NON-SHIFT DIFFERENTIAL RATE FOR THIS CLASSIFICATION AS PUBLISHED IN THE DIRECTOR'S GENERAL PREVAILING WAGE DETERMINATIONS.
- H IN ADDITION, AN AMOUNT EQUAL TO 3% OF THE BASIC HOURLY RATE IS ADDED TO THE TOTAL HOURLY RATE AND OVERTIME HOURLY RATES FOR THE NATIONAL EMPLOYEES BENEFIT BOARD. PURSUANT TO LABOR CODE SECTIONS 1773.1 AND 1773.8, THE AMOUNT PAID FOR THIS EMPLOYER PAYMENT MAY VARY RESULTING IN A LOWER TAXABLE BASIC HOURLY WAGE RATE, BUT THE TOTAL HOURLY RATES FOR STRAIGHT TIME AND OVERTIME MAY NOT BE LESS THAN THE GENERAL PREVAILING RATE OF PER DIEM WAGES.
- I INCLUDED IN STRAIGHT-TIME HOURLY RATE.
- J RATE APPLIES TO THE FIRST 2 DAILY OVERTIME HOURS. FOR ALL HOURS AFTER THE FIRST 2 DAILY OVERTIME HOURS, USE THE SUNDAY AND HOLIDAY NON-SHIFT DIFFERENTIAL RATE.
- K DISREGARD THIS RATE. FOR THE FIRST 10 HOURS OF WORK ON SATURDAY, USE THE SATURDAY NON-SHIFT DIFFERENTIAL RATE. FOR ALL HOURS AFTER THE FIRST 10 HOURS WORKED ON SATURDAY, USE THE SUNDAY AND HOLIDAY NON-SHIFT DIFFERENTIAL RATE.
- L THE MAXIMUM ALLOWABLE RATIO IS ONE TRANSPORTATION SYSTEMS TECHNICIAN TO ONE JOURNEYMAN ON EACH JOB.
- M INCLUDES AN AMOUNT WITHHELD FOR ADMINISTRATIVE DUES WHICH IS NOT FACTORED INTO OVERTIME AND AN AMOUNT FOR VACATION WHICH IS FACTORED AT 1.5 TIMES FOR ALL OVERTIME.
- N INCLUDES AMOUNT FOR NATIONAL PENSION AND RETIREE'S X-MAS FUND.
- O AMOUNT INCLUDED IN BASIC HOURLY RATE AND FACTORED AT 1.5 TIMES FOR ALL OVERTIME.
- P INCLUDES AN AMOUNT FOR THE P.I.P.E. LABOR MANAGEMENT COOPERATION COMMITTEE AND THE CONTRACTOR EDUCATION & DEVELOPMENT FUND.
- Q RATE APPLIES TO THE FIRST 2 DAILY OVERTIME HOURS AND THE FIRST 10 HOURS ON SATURDAY; ALL OTHER TIME IS PAID AT THE SUNDAY AND HOLIDAY OVERTIME HOURLY RATE.
- R SATURDAYS IN THE SAME WORK WEEK MAY BE WORKED AT STRAIGHT-TIME IF JOB IS SHUT DOWN DURING THE NORMAL WORKWEEK DUE TO INCLEMENT WEATHER.
- S PIPE TRADESMEN SHALL NOT BE PERMITTED ON ANY JOB WITHOUT A JOURNEYMAN.
- T INCLUDES AN AMOUNT WITHHELD FOR ADMINISTRATIVE DUES WHICH IS NOT FACTORED IN THE OVERTIME RATES.
- U INCLUDES AMOUNT WITHHELD FOR ADMINISTRATIVE DUES.
- V TRADESMEN SHALL ONLY BE USED IF THE FIRST WORKER ON THE JOB IS A LANDSCAPE/IRRIGATION FITTER, SECOND WORKER MUST BE A LANDSCAPE/IRRIGATION FITTER OR APPRENTICE LANDSCAPE/IRRIGATION FITTER. THE 3RD AND 4TH MAY BE A TRADESMAN. THE 5TH MUST BE A LANDSCAPE/IRRIGATION FITTER AND THEREAFTER TRADESMEN WILL BE REFERRED ON A 50-50 BASIS, TO JOURNEYMAN OR APPRENTICE.
- W INCLUDES AN AMOUNT FOR 401A PLAN.
- X INCLUDES AN AMOUNT FOR THE P.I.P.E. LABOR MANAGEMENT COOPERATION COMMITTEE TRUST FUND AND FOR PROMOTION FUND.
- Y SATURDAY MAY BE PAID AT STRAIGHT TIME IF THE WORK WEEK IS TUESDAY THROUGH SATURDAY.
- Z RATE APPLIES TO WORK ON HOLIDAYS ONLY; SUNDAYS ARE PAID AT THE SATURDAY OVERTIME HOURLY RATE.
- AA RATE APPLIES TO LOS ANGELES CITY LIMITS AND TWENTY-FIVE (25) MILES BEYOND CITY LIMITS OF LOS ANGELES.
- AB AMOUNT IS FOR INDUSTRY PROMOTION FUND AND P.I.P.E. FUND.
- AC RATE APPLIES TO THE FIRST 4 DAILY OVERTIME HOURS AND THE FIRST 10 HOURS ON SATURDAY; ALL OTHER TIME IS PAID AT THE SUNDAY AND HOLIDAY OVERTIME HOURLY RATE.

RECOGNIZED HOLIDAYS: HOLIDAYS UPON WHICH THE GENERAL PREVAILING HOURLY WAGE RATE FOR HOLIDAY WORK SHALL BE PAID, SHALL BE ALL HOLIDAYS IN THE COLLECTIVE BARGAINING AGREEMENT, APPLICABLE TO THE PARTICULAR CRAFT, CLASSIFICATION, OR TYPE OF WORKER EMPLOYED ON THE PROJECT, WHICH IS ON FILE WITH THE DIRECTOR OF INDUSTRIAL RELATIONS. IF THE PREVAILING RATE IS NOT BASED ON A COLLECTIVELY BARGAINED RATE, THE HOLIDAYS UPON WHICH THE PREVAILING RATE SHALL BE PAID SHALL BE AS PROVIDED IN SECTION 6700 OF THE GOVERNMENT CODE. YOU MAY OBTAIN THE HOLIDAY PROVISIONS FOR THE CURRENT DETERMINATIONS

ON THE INTERNET AT [HTTP://WWW.DIR.CA.GOV/OPRL/DPreAgeDetermination.htm](http://www.dir.ca.gov/OPRL/DPreAgeDetermination.htm). HOLIDAY PROVISIONS FOR THE CURRENT OR SUPERSEDED DETERMINATIONS MAY BE OBTAINED BY CONTACTING THE OFFICE OF THE DIRECTOR - RESEARCH UNIT AT (415) 783-4774.

TRAVEL AND/OR SUBSISTENCE: IN ACCORDANCE WITH LABOR CODE SECTIONS 1773.1 AND 1773.9, CONTRACTORS SHALL MAKE TRAVEL AND/OR SUBSISTENCE PAYMENTS TO EACH WORKER TO EXECUTE THE WORK. YOU MAY OBTAIN THE TRAVEL AND/OR SUBSISTENCE PROVISIONS FOR THE CURRENT DETERMINATIONS ON THE INTERNET AT [HTTP://WWW.DIR.CA.GOV/OPRL/DPreAgeDetermination.htm](http://www.dir.ca.gov/OPRL/DPreAgeDetermination.htm). TRAVEL AND/OR SUBSISTENCE REQUIREMENTS FOR CURRENT OR SUPERSEDED DETERMINATIONS MAY BE OBTAINED BY CONTACTING THE OFFICE OF THE DIRECTOR - RESEARCH UNIT AT (415) 783-4774.

# GENERAL PREVAILING WAGE APPRENTICE RATES

## APPRENTICE INFORMATION

*Determination:* 2020--1      *Issue Date:* 02-22-2020      *Expire Date:* 07-26-2020      \*\*      *Page:* 1

*Craft/Classification:* Electrician, Inside Wireman      *Shift:* 1

County: Los Angeles

Period	Duration Months	OJT Hours	Hourly Basic Rate	Health & Welfare	Pension	Vacation /Holiday	Training	Other	Hourly Total Rate
1	6		\$19.380	\$11.790	\$ .580		\$ .810	\$ .500	\$33.060
2	6		\$21.800	\$11.790	\$ .650		\$ .810	\$ .500	\$35.550
3	6		\$24.230	\$12.790	\$8.020		\$ .810	\$ .500	\$46.350
4	6		\$26.650	\$12.790	\$8.810		\$ .810	\$ .500	\$49.560
5	6		\$29.070	\$12.790	\$9.610		\$ .810	\$ .500	\$52.780
6	6		\$31.490	\$12.790	\$10.410		\$ .810	\$ .500	\$56.000
7	6		\$33.920	\$12.790	\$11.220		\$ .810	\$ .500	\$59.240
8	6		\$36.340	\$12.790	\$12.020		\$ .810	\$ .500	\$62.460
9	6		\$38.760	\$12.790	\$12.820		\$ .810	\$ .500	\$65.680
10	6		\$41.180	\$12.790	\$13.620		\$ .810	\$ .500	\$68.900

**Footnote(s):**

Pension -- includes amounts for defined contribution and benefit plans for apprentices above Period 2. Includes an amount equal to 3% of the basic hourly rate for the National Employees Benefit Fund which is factored at the applicable overtime multiplier for each overtime hour. Pursuant to Labor Code Sections 1773.1 and 1773.8 the amount paid for this employer payment may vary resulting in a lower taxable basic hourly wage rate, but the total hourly rates for straight time and overtime may not be less than the general prevailing rate of per diem wages.

Vacation/Holiday included in the Basic Hourly Rate.

**Journeyman Predetermined Increases:**

- 7/27/2020: \$1.85 to be allocated to wages and/or fringes.
- 2/1/2021: \$1.90 to be allocated to wages and/or fringes.
- 7/26/2021: \$2.05 to be allocated to wages and/or fringes.
- 1/31/2022: \$2.10 to be allocated to wages and/or fringes.

There may be corresponding predetermined increase(s) to the apprentices associated with this journeyman craft/classification. Please fax a request to (415) 703-4771 or send to the following address:

Department of Industrial Relations, Office of the Director - Research Unit  
 P.O. Box 420603  
 San Francisco, CA 94142-0603

Apprentice Prevailing Wage Rates are paid only to apprentices registered with the State of California, Division of Apprenticeship Standards, for work the registered apprentice performs in his/her specific craft or trade. You may check whether an Apprentices is registered at <http://www.dir.ca.gov/DAS/appcertpw/AppCertSearch.asp>



## GENERAL PREVAILING WAGE APPRENTICE RATES

### APPRENTICE INFORMATION

*Determination:* 2020--1      *Issue Date:* 02-22-2020      *Expire Date:* 07-26-2020      \*\*      *Page:* 2

*Craft/Classification:* Electrician, Inside Wireman      *Shift:* 2

County: Los Angeles

Period	Duration Months	OJT Hours	Hourly Basic Rate	Health & Welfare	Pension	Vacation /Holiday	Training	Other	Hourly Total Rate
1	6		\$22.730	\$11.790	\$.680		\$.810	\$.500	\$36.510
2	6		\$25.570	\$11.790	\$.770		\$.810	\$.500	\$39.440
3	6		\$28.420	\$12.790	\$8.140		\$.810	\$.500	\$50.660
4	6		\$31.260	\$12.790	\$8.950		\$.810	\$.500	\$54.310
5	6		\$34.100	\$12.790	\$9.760		\$.810	\$.500	\$57.960
6	6		\$36.940	\$12.790	\$10.580		\$.810	\$.500	\$61.620
7	6		\$39.790	\$12.790	\$11.390		\$.810	\$.500	\$65.280
8	6		\$42.630	\$12.790	\$12.210		\$.810	\$.500	\$68.940
9	6		\$45.470	\$12.790	\$13.020		\$.810	\$.500	\$72.590
10	6		\$48.300	\$12.790	\$13.830		\$.810	\$.500	\$76.230

**Footnote(s):**

Pension -- includes amounts for defined contribution and benefit plans for apprentices above Period 2. Includes an amount equal to 3% of the basic hourly rate for the National Employees Benefit Fund which is factored at the applicable overtime multiplier for each overtime hour. Pursuant to Labor Code Sections 1773.1 and 1773.8 the amount paid for this employer payment may vary resulting in a lower taxable basic hourly wage rate, but the total hourly rates for straight time and overtime may not be less than the general prevailing rate of per diem wages.

Vacation/Holiday included in the Basic Hourly Rate.

**Journeyman Predetermined Increases:**

7/27/2020: \$1.85 to be allocated to wages and/or fringes.

2/1/2021: \$1.90 to be allocated to wages and/or fringes.

7/26/2021: \$2.05 to be allocated to wages and/or fringes.

1/31/2022: \$2.10 to be allocated to wages and/or fringes.

There may be corresponding predetermined increase(s) to the apprentices associated with this journeyman craft/classification. Please fax a request to (415) 703-4771 or send to the following address:

Department of Industrial Relations, Office of the Director - Research Unit  
P.O. Box 420603  
San Francisco, CA 94142-0603

Apprentice Prevailing Wage Rates are paid only to apprentices registered with the State of California, Division of Apprenticeship Standards, for work the registered apprentice performs in his/her specific craft or trade. You may check whether an Apprentices is registered at <http://www.dir.ca.gov/DAS/appcertpw/AppCertSearch.asp>

## GENERAL PREVAILING WAGE APPRENTICE RATES

### APPRENTICE INFORMATION

*Determination:* 2020--1      *Issue Date:* 02-22-2020      *Expire Date:* 07-26-2020      \*\*      *Page:* 3

*Craft/Classification:* Electrician, Inside Wireman      *Shift:* 3

County: Los Angeles

Period	Duration Months	OJT Hours	Hourly Basic Rate	Health & Welfare	Pension	Vacation /Holiday	Training	Other	Hourly Total Rate
1	6		\$25.470	\$11.790	\$ .760		\$ .810	\$ .500	\$39.330
2	6		\$28.650	\$11.790	\$ .860		\$ .810	\$ .500	\$42.610
3	6		\$31.840	\$12.790	\$8.250		\$ .810	\$ .500	\$54.190
4	6		\$35.020	\$12.790	\$9.060		\$ .810	\$ .500	\$58.180
5	6		\$38.200	\$12.790	\$9.890		\$ .810	\$ .500	\$62.190
6	6		\$41.380	\$12.790	\$10.710		\$ .810	\$ .500	\$66.190
7	6		\$44.570	\$12.790	\$11.540		\$ .810	\$ .500	\$70.210
8	6		\$47.750	\$12.790	\$12.360		\$ .810	\$ .500	\$74.210
9	6		\$50.930	\$12.790	\$13.190		\$ .810	\$ .500	\$78.220
10	6		\$54.110	\$12.790	\$14.000		\$ .810	\$ .500	\$82.210

**Footnote(s):**

Pension -- includes amounts for defined contribution and benefit plans for apprentices above Period 2. Includes an amount equal to 3% of the basic hourly rate for the National Employees Benefit Fund which is factored at the applicable overtime multiplier for each overtime hour. Pursuant to Labor Code Sections 1773.1 and 1773.8 the amount paid for this employer payment may vary resulting in a lower taxable basic hourly wage rate, but the total hourly rates for straight time and overtime may not be less than the general prevailing rate of per diem wages.

Vacation/Holiday included in the Basic Hourly Rate.

**Journeyman Predetermined Increases:**

- 7/27/2020: \$1.85 to be allocated to wages and/or fringes.
- 2/1/2021: \$1.90 to be allocated to wages and/or fringes.
- 7/26/2021: \$2.05 to be allocated to wages and/or fringes.
- 1/31/2022: \$2.10 to be allocated to wages and/or fringes.

There may be corresponding predetermined increase(s) to the apprentices associated with this journeyman craft/classification. Please fax a request to (415) 703-4771 or send to the following address:

Department of Industrial Relations, Office of the Director - Research Unit  
P.O. Box 420603  
San Francisco, CA 94142-0603

Apprentice Prevailing Wage Rates are paid only to apprentices registered with the State of California, Division of Apprenticeship Standards, for work the registered apprentice performs in his/her specific craft or trade. You may check whether an Apprentices is registered at <http://www.dir.ca.gov/DAS/appcertpw/AppCertSearch.asp>