

**CUT IN METHOD**

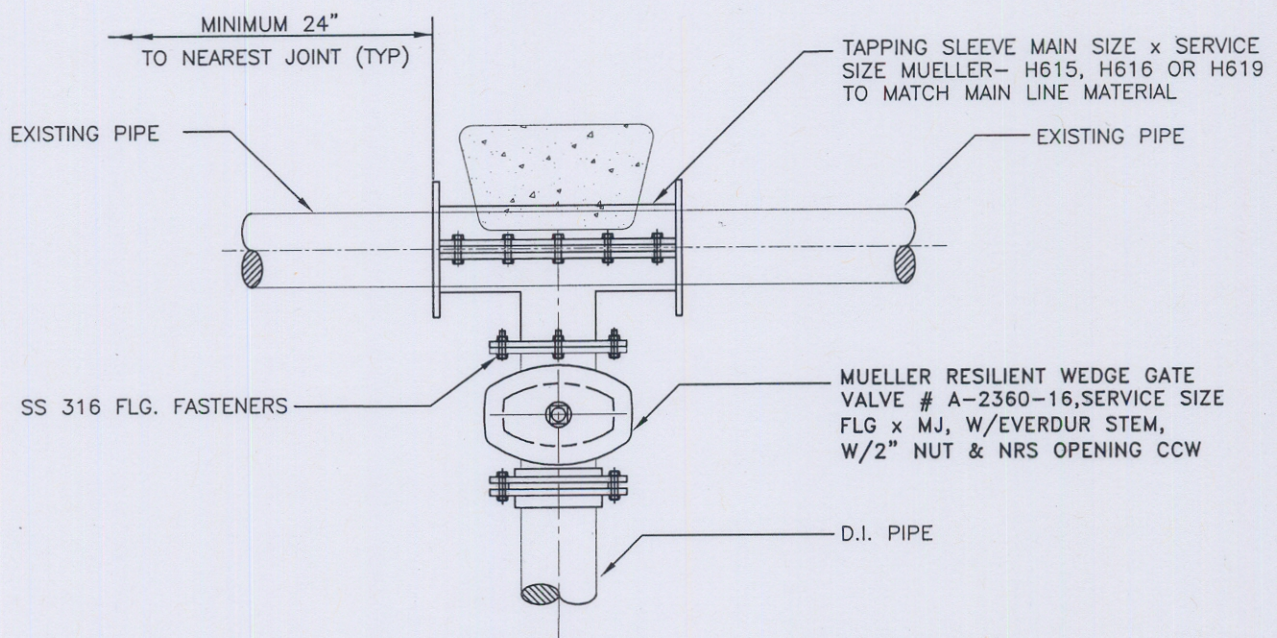

**HOT TAP METHOD**

ACCOMPANYING STD. T700, T701, T712, AND T713

**CITY OF TORRANCE**

**D.I. CONNECTION TO MAIN**

STANDARD NO.

DATE ISSUED

JAN 2011

**T 723**

ROBERT J. BESTE  
PUBLIC WORKS DIRECTOR  
R.C.E. NO. 50737

*Handwritten signature: RJA / RJA*

SHEET 1 OF 1

x:\ENG\VPrescd\Water Standards\T723.dwg 2/08/11 14:18 vprescd