

ELEVATION

D.I. TEE, MJxFLG OR TAPPING SLEEVE (MUELLER: H615, H616 OR H619)

MUELLER NO.A2362-16 GATE VALVE MJxFLG, W/EVERDUR STEM & SS 316 FASTENERS W/2" NUT & NRS OPENING CCW.

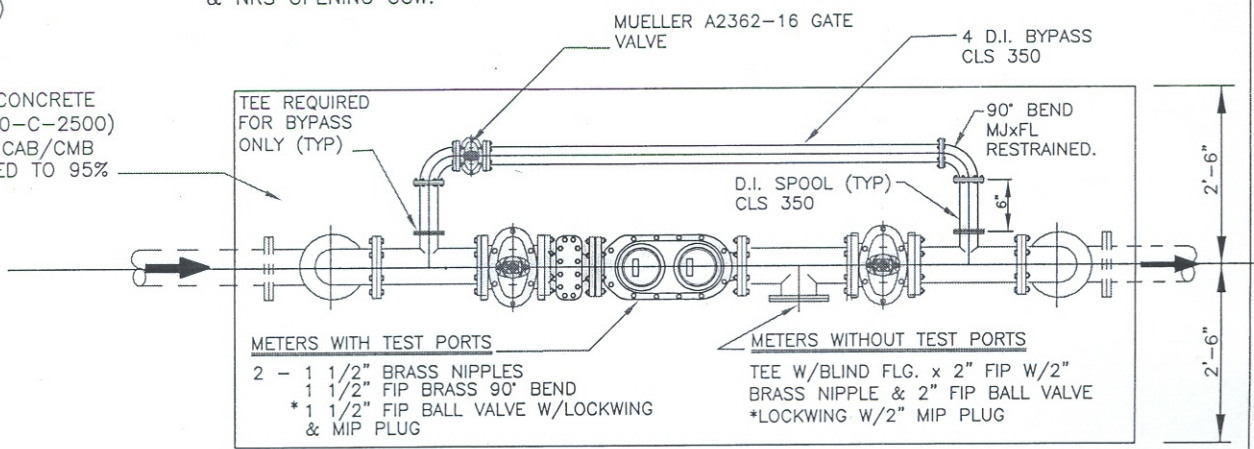

PARTIAL PLAN

*2" BALL VALVE W/LOCKWING } FORD B11-777WNL
JONES E-1900W

*1 1/2" BALL VALVE W/LOCKWING } FORD B11-666WNL
JONES E-1900W

NOTE:

- 1) D.I. PIPE SIZES 6", 8", 10".
- 2) IF BYPASS IS REQUIRED, IT SHALL BE 4" D.I. PIPE.
- 3) ALL JOINTS FLANGED UNLESS OTHERWISE SHOWN. ALL FASTENERS SHALL BE 316 ST. STEEL
- 4) GATE VALVES SHALL HAVE EVERDUR STEMS, & NRS OPENING CCW.

ACCOMPANYING STD'S T700, T701, T712, T713 AND T723.

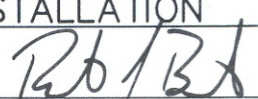
CITY OF TORRANCE		
TYPICAL 6" - 10" ABOVE GROUND METER INSTALLATION		
DATE ISSUED	ROBERT J. BESTE PUBLIC WORKS DIRECTOR R.C.E. NO. 50737 	STANDARD NO.
NOV 2015		T 718
		SHEET 1 OF 1