

ELEVATION

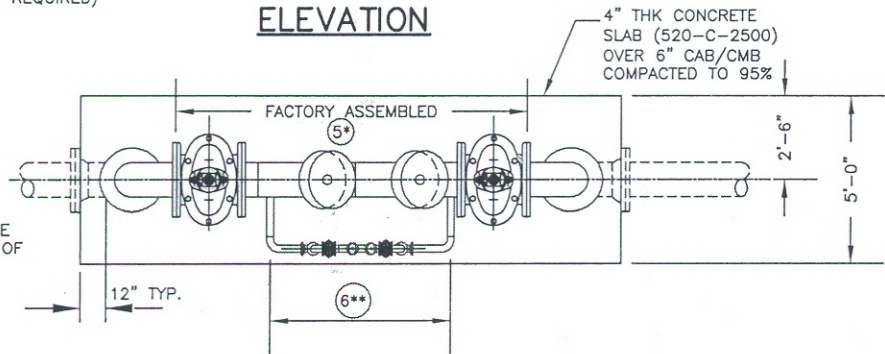

PARTIAL PLAN

NOTE:
IF IN PAVED AREA SET PAD FLUSH WITH FINISHED GRADE.

*REDUCED PRESSURE PRINCIPLE DETECTOR ASSEMBLY W/RESILIENT SEATED OS & Y SHUT-OFF VALVES APPROVED BY THE CALIFORNIA DEPARTMENT OF HEALTH SERVICES OFFICE OF DRINKING WATER AND THE LOS ANGELES COUNTY DEPARTMENT OF PUBLIC HEALTH.

**OMIT IF REDUCED PRESSURE PRINCIPLE DETECTOR ASSEMBLY WILL BE SUPPLIED BY METERED WATER.

ASSEMBLY SHALL BE TESTED BY A CITY APPROVED TESTER CERTIFIED BY THE LOS ANGELES COUNTY DEPT. OF PUBLIC HEALTH. THE DEVELOPER/OWNER IS RESPONSIBLE FOR THE COST OF TESTING THE ASSEMBLY.

ITEM	DESCRIPTION	SIZE
①	D.I. WATER PIPE (CLASS 350)	
②	90°, D.I. ELBOW, MJ X FLG, CLS 350	SERVICE SIZE
③	D.I. SPOOL, CLS 350 (BOTH ENDS SHALL BE FLANGED) (UNI-FLANGE SHALL NOT BE USED)	
④	90°, D.I. ELBOW, FLG. CLS 350.	
⑤	REDUCED PRESSURE PRINCIPLE ASSEMBLY	
⑥	3/4" COPPER BY-PASS ASSEMBLY (NEPTUNE WATER METER, E-CODER) R900i v4 CUBIC FEET REGISTER). (3)-3/4" FIP BALL VALVES W/LOCKWING (JONES E1908, FORD B13-332WNL)	5/8"
⑦	VALVE BOX ASSEMBLY PER T712	
⑧	MUELLER NO.A2362-16 GATE VALVE, MJxFLG, W/EVERDUR STEM & SS 316 FASTENERS W/2" NUT & NRS OPENING CCW.	
⑨	M.J. x FLG. DUCTILE IRON TEE OR TAPPING SLEEVE (MUELLER: H615, H616 OR H619)	

CITY OF TORRANCE

REDUCED PRESSURE PRINCIPLE DETECTOR ASSEMBLY > 2"

STANDARD NO.

T 711

SHEET 1 OF 1

DATE ISSUED
NOV 2015

ROBERT J. BESTE
PUBLIC WORKS DIRECTOR
R.C.E. NO. 50737

[Handwritten Signature]

X:\ENG\WProsad\Water Standards\T711.dwg 11/19/15 09:47 vprasad