

c:\Documents and Settings\yprasad\My Documents\Drawing3.dwg 2/08/11 11:51 yprasad

FOR MULTIPLE TAPS
ALTERNATE AT 45° TO
EACH OTHER

COPPER FLARE NUT
(SEE T703) OR PACK JOINT
(SEE T704)

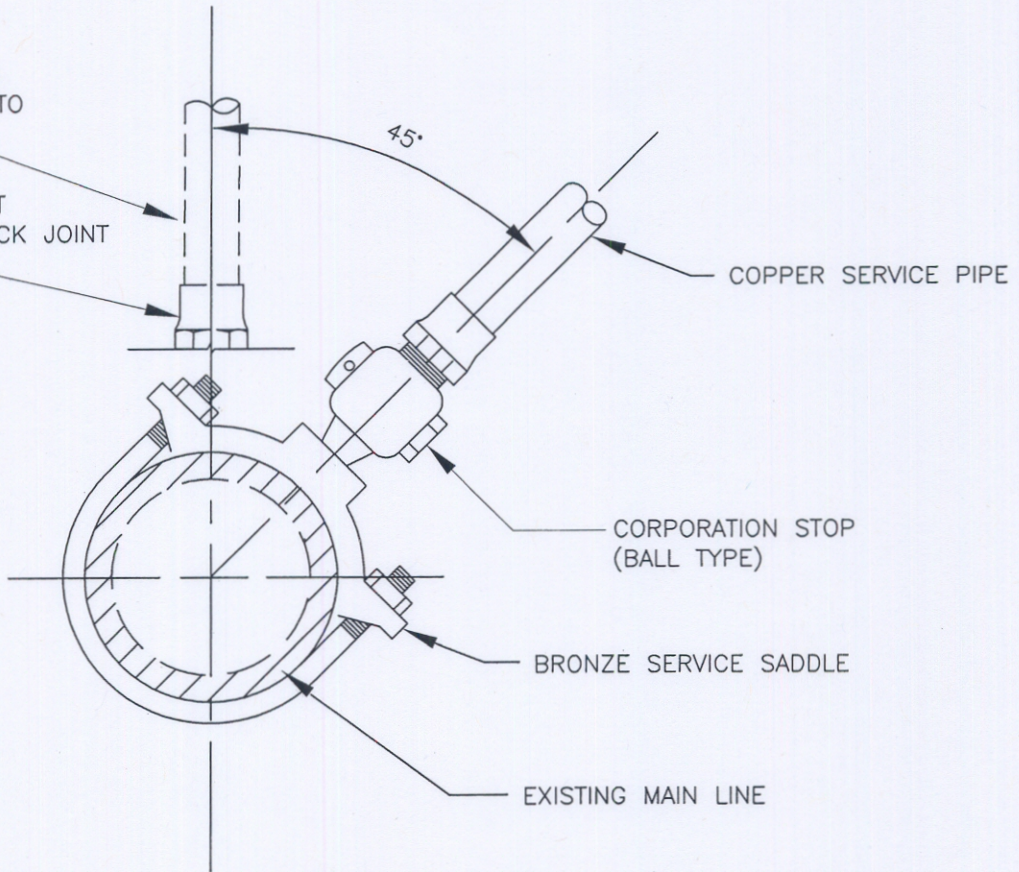

NOTES:

1. MINIMUM DISTANCE BETWEEN TAPS OR CONNECTIONS SHALL BE 20 INCHES, AND A MINIMUM OF 18 INCHES FROM END OF PIPE.
2. FOR STEEL MAINS DELETE SERVICE SADDLE. A TAP NOZZLE SHALL BE WELDED TO MAIN AND AN INSULATING BUSHING SHALL BE INSTALLED BETWEEN THE TAP NOZZLE AND THE CORPORATION STOP. FOR PIPES WITH WALL THICKNESS THINNER THAN 16 GAUGE, A REINFORCEMENT COLLAR PLATE OR FULL WRAP REINFORCEMENT PLATE SHALL BE INSTALLED AS DETERMINED BY THE ENGINEER.

ACCOMPANYING STD.'S T700 AND T703 OR T704.

CITY OF TORRANCE		
1" & 2" SERVICE CONNECTION TO MAIN LINE		STANDARD NO.
DATE ISSUED		T 702
JAN 2011	ROBERT J. BESTE PUBLIC WORKS DIRECTOR R.C.E. NO. 50737 <i>RB / BA</i>	SHEET 1 OF 1